

General Specifications

Model RAMC Metal Short-stroke Rotameter

GS 01R01B02-00E-E

A float is guided concentrically to a special shaped conic metal tube. The position of this float is magnetically transmitted to the indicator. The short-tube Rotameter is used for measurement of flow rates of liquids and gases. Its special application is in troubled, opaque or aggressive mediums. The instrument is mounted in a vertical pipeline with flow direction upwards. The indicators are exchangeable without influence on the accuracy.

FEATURES

- Different process connections like flanges according EN and ASME
- All wetted parts in stainless steel or PTFE
- Maximum flow 0.025 - 130 m³/h water resp. 0.75 - 1400 m³/h air (20 °C / 1.013 bar abs)
- Measuring accuracy acc. Directive VDI/VDE 3513 sheet 2 (q_G=50%)
- Float damping to avoid float bouncing with gas applications
- Optional heat tracing (with steam or fluid heat carrier)
- Indicator in stainless steel, aluminium, protection class IP66/67
- Local indicator without additional power supply
- Microprocessor controlled transmitter with 24 V, 115 V or 230 V power supply
- Intrinsically safe version (Ex-i): ATEX, IECEx, FM, CSA, NEPSI, PESO, KOSHA
- Flame proof version (Ex-d): ATEX, IECEx, NEPSI, PESO, KOSHA
- Dust explosion proof: ATEX, IECEx, NEPSI, PESO, KOSHA
- Suitable for SIL application, FMEDA report available
- Limit switches, also available as "Fail Safe" version

Electronic transmitter as standard with local-controlling display with the following features :

- Flow indication (totalize, actual, percent)
- Indication of different volume- and mass flow units
- Second (manual) calibration storing
- Patented float blocking indication function
- Signal output damping
- Error message indication
- Temperature measurement in the electronic transmitter
- HART- communication
- Profibus PA- communication

Contents	
Features	page 1
Standard Specifications	page 2
Compliance with IEC 61508	page 4
Compliance with ISO 13849	page 4
Hazardous Area Specifications	page 5
Installation	page 10
Model Specifications	page 13
Options	page 14
Process connection table for metal tubes	page 16
Flow tables metal tubes	page 17
Process connection and flow table for tubes with PTFE lining	page 18
Temperature graphs	page 19
Dimensions and weights	page 21



RAMC with housing type 90



RAMC with housing type 91

STANDARD SPECIFICATIONS

MEASURING TUBE

Materials of wetted parts :

- Stainless steel AISI 316L (1.4404)
- PTFE
- Aramide fibres / NBR binder (Gasket for process connection R4 or T4)
- Other materials on request

Fluids to be measured :

suitable for a variety of liquids, gas and steam

Measuring range :

See table 11 and 12

Measuring range ratio :

10:1

Process connections / Stainless steel :

- Flanges : - acc. EN1092-1
 - DN100 – DN150 PN16
 - DN15 – DN100 PN40
 - DN50 – DN80 PN63
 - DN15 – DN50 PN100
 - acc. ASME B 16.5
 - ½" – 6" Class 150 raised face
 - ½" – 6" Class 300 raised face
 - ½" – 3" Class 600 raised face
- Roughness of sealing
- | | |
|-----------|--------------|
| Form B1 : | RA 3.2 - 6.3 |
| Form B2 : | RA 0.8 - 3.2 |
| ASME : | RA 3.2 - 6.3 |

- Threaded connection :

- male acc. DIN 11851
- NPT- female
- G- female
- Clamp acc. DN25 / 1" – DN100 / 4"

Process pressure :

Depends on process connection, see table 10 to 12 higher pressure (up to 700 bar) on request

Process temperature :

- medium wetted parts made of stainless steel
 - : -200 ... +370 °C
- medium wetted parts made of PTFE
 - : -80 ... +130 °C

See fig. 7a to 7c

Measuring accuracy :

Table 1

Material of wetted parts	Size	Measuring accuracy acc. Directive VDI/ VDE 3513 sheet 2 ($q_G=50\%$)
SS	DN 15 - 100	1.6%
SS	DN 125 - 150	2.5%
PTFE	DN 15 -100	2.5%

Pressure Equipment Directive (PED) Directive 97/23/EG :

Tubes :

- Modul : H
- Fluid Group : 1 (dangerous fluids)
- Produced acc. to category : III
- Classification : Table 6 (piping)

Heating (options /T1 to /T6) :

- Art. 3 section 3 : (Volume < 1L)
- Fluid Group : 2 (non-dangerous fluids)
- Classification : Table 2 (vessels)

CANADIAN REGISTRATION NUMBERS (CRN) available upon request

Installation :

- Mounting direction : vertical
- Flow direction : upwards
- Mounting length : see tables 10, 12, 13, 14
- Straight pipe inlet length : DN 80/100 at least 5D, not necessary for smaller sizes

Weight :

See table 15

LOCAL INDICATOR

(Indicator/Transmitter Code -T)

Principle :

The indication is made by magnetic coupling of a magnet enclosed in the float and a magnet in the indication unit, which follows the movements of the float, with a pointer.

Indicator housing :

- Materials : - Stainless steel (1.4301 / 304) (housing type 90)
- painted aluminium casting (housing type 91) each with safety-glass window
- Degree of protection : - IP66/67

Scales :

- Standard : removable aluminium plate with scale (double scale as option)
- Marking : direct readable units or percentage of Qmax.

Transportation- and Storage condition :

-40°C to +110°C

ELECTRONIC TRANSMITTER

(Indicator/Transmitter Code -E, -H, -G)

Standard type (Code -E) :

Power supply :

- 4- wire units with galvanic isolation :
 - 230 V AC +10 %/-15 %, 50/60 Hz, fuse 0.063 A, time lag, (5x20) mm
 - 115 V AC +10%/-15 %, 50/60 Hz, fuse 0.125 A, time lag, (5x20) mm
- 2/3- wire units : - U = 14 V ... 30 V DC

Output signal :

- 4- wire units : - 0 - 20 mA, 4 - 20 mA
- pulse output (option /CP) max. frequency 4 Hz see fig. 3-5
- 3- wire units : 0 - 20 mA, 4 - 20 mA
- 2- wire units : 4 - 20 mA

The 20 mA point is selectable between 60% and 100% of Qnom.

Load resistance :

- 4- wire units : $\leq 500 \Omega$
- 2/3- wire unit : $\leq (U - 14 V) / 20 \text{ mA}$, max. 500 Ω

HART- communication type (Code -H) :

Power supply :

- 2-wire units : U = 14 V ... 30 V DC

Output signal :

- 2- wire units : 4 - 20 mA

Load resistance :

- HART-version : 250 ... 500 Ω

Profibus PA - communication type (Code -G) :

- 2- wire bus connection not polarity sensitive : 9 ... 32 V DC acc. to IEC 61568-2 and FISCO model
- Basic current : 14 mA
- Failure current (FDE) : 10 mA additional to basic current
- Transmission rate : 31.25 kBaud
- AI block for volume flow or mass flow
- Configurable with PDM DD
- Supports I&M- functions

Digital display :

8- digits 7- segment-LC-display character height 6 mm

Process-/ Ambient temperature :

The dependency of the process temperature from the ambient temperature is shown in fig. 7a to fig. 7c.

The internal temperature of the electronic transmitter can be indicated on the display or checked via HART communication.

Measurement of the internal transmitter temperature :

- Range : -25 °C to +70 °C

- Accuracy : ± 5 °C

Transportation- and Storage condition :

-40 °C to +70 °C

Linearity ¹⁾ :

± 0.2 % f.s.

Hysteresis ¹⁾ :

± 0.1 % f.s.

Repeatability ¹⁾ :

± 0.1 % f.s.

Influence of power supply ¹⁾ :

± 0.1 % f.s.

Temperature coefficient of the output signal ¹⁾ :

± 0.5 % /10 K f.s.

AC-part of output signal ¹⁾ :

± 0.15 % f.s.

Long-time stability ¹⁾ :

± 0.2 % /year

Max. output signal :

21.5 mA

Output signal in case of failure :

≤ 3.6 mA (acc. NE 43)

Response time (99%) :

About 1.5 s (damping 1s)

Electromagnetic compatibility (EMC) :

- Acc. EN 61326-1: 2006, Class A, Table 2 and

EN 61326-2-3 : 2006 :

Criterion A, restriction: HF- immunity between 500 MHz and 750 MHz : criterion B

RAMC with Profibus PA :

Criterion A: Burst, Surge, HF- Immunity

Criterion B: ESD

In case of single sided grounding of the cable shield it is possible that for all tests criterion B is reached.

Unit safety acc. DIN EN 61010-1: 2001 :

- Over voltage category : II (acc. VDE 0110 or IEC 664)

- Pollution degree : I

- Safety class : I (with 115 / 230V AC power supply)
III (with 24V DC power supply and
Fieldbus type)

POWER SUPPLY FOR ELECTRONIC TRANSMITTER

(Option /UT)

Type :

Power supply with galvanically separated input and output
- RN221N-B1, HART- compatible

Supply voltage :

20 ... 250 V DC / AC 50/60 Hz

Maximum load :

700 Ω

Output signal :

4 - 20 mA

CABLE GLAND (for transmitter -E, -H and -G) :**Size :**

- M16x1.5 (standard)

- Thread M20x1.5 (option /A13; standard for option /KF1)

- Thread ½" NPT (option /A5)

Cable diameter :

6 – 9 mm

Maximum cross section of core :

Ø 1.5 mm²

LIMIT SWITCHES IN STANDARD VERSION

(option /K1 to /K3)

Type :

Inductive proximity switch SC3.5-N0 acc. DIN EN 60947-5-6

Nominal voltage :

8 V DC

Output signal :

≤ 1 mA or ≥ 3 mA

LIMIT SWITCHES IN FAIL SAFE VERSION

(option /K6 to /K10)

Type :

Inductive proximity switch SJ3.5-SN; SJ3.5-S1N

acc. DIN EN 60947-5-6 (NAMUR)

Nominal voltage :

8 V DC

Output signal :

≤ 1 mA or ≥ 3 mA

HYSTERESIS OF LIMIT SWITCHES**Min-contact / Max-contact :**

- pointer movement ≈ 0.8 mm

- float movement ≈ 0.8 mm

Minimum distance between 2 contacts :

≈ 2 mm

CABLE GLAND (option /K1 to /K10)**Size :**

- M16x1.5 (standard)

- Thread M20x1.5 (option /A13; standard for option /KF1)

- Thread ½" NPT (option /A5)

Cable diameter :

6 – 9 mm

Maximum cross section of core :

Ø 1.5 mm²

POWER SUPPLY FOR LIMIT SWITCHES (Option /W__)**Type :**

acc. DIN EN 60947-5-6 (NAMUR)

- KFA5-SR2-Ex*-W (115 V AC), * = 1 or 2

- KFA6-SR2-Ex*-W (230 V AC), * = 1 or 2

- KFD2-SR2-Ex*-W (24 V DC), * = 1 or 2

- KHA6-SH-Ex1 (115/230 V AC), Fail Safe, 1 channel

- KFD2-SH-Ex1 (24 V DC), Fail Safe, 1 channel

Power supply :

- 230 V AC ± 10%, 45-65Hz

- 115 V AC ± 10%, 45-65Hz

- 24 V DC ± 25%

Relay output :

1 or 2 potential-free changeover contact(s)

Switching capacity :

max. 250 V AC, max. 2 A

Note :

If Fail-Safe limit switch option /K6 or /K7 is ordered, for power supply option /W2E or /W4E must be selected.

If Fail-Safe limit switch option /K8, /K9 or /K10 is ordered, for power supply option /W2F or /W4F must be selected.

¹⁾ referenced to 20°C ambient temperature

SWITCHING LEVELS FOR LIMIT SWITCHES**Table 2 Min, Max and Min-Max-contact in standard version**

		Option /K1	Option /K2	Option /K3
Function	Pointer	Signal	Signal	Signal
		SC3,5-N0	SC3,5-N0	SC3,5-N0
MAX	above LV	----	1 mA	1 mA
	below LV	----	3 mA	3 mA
Function	Pointer	Signal	Signal	Signal
		SC3,5-N0	SC3,5-N0	SC3,5-N0
MIN	above LV	3 mA	----	3 mA
	below LV	1 mA	----	1 mA

Note: LV = Limit value

Table 3 Min, Max and Min-Max-contact in fail-safe version

		Option /K6	Option /K7	Option /K8
Function	Pointer	Signal	Signal	Signal
		SJ3,5-SN	SJ3,5-SN	SJ3,5-SN
MAX	above LV	----	1 mA	1 mA
	below LV	----	3 mA	3 mA
	Fail Safe	----	1 mA	1 mA
Function	Pointer	Signal	Signal	Signal
		SJ3,5-SN	SJ3,5-SN	SJ3,5-SN
MIN	above LV	3 mA	----	3 mA
	below LV	1 mA	----	1 mA
	Fail Safe	1 mA	----	1 mA

Note: LV = Limit value

Table 4 Limit switch as Min-Min-contact in fail-safe version

		Option /K9
Function	Pointer	Signal
		SJ3,5-S1N
MIN	above LV	3 mA
	below LV	1 mA
	Fail Safe	1 mA
Function	Pointer	Signal
		SJ3,5-SN
MIN	above LV	3 mA
	below LV	1 mA
	Fail Safe	1 mA

Note: LV = Limit value

Table 5 Limit switch as Max-Max-contact in fail-safe version

		Option /K10
Function	Pointer	Signal
		SJ3,5-SN
MAX	above LV	1 mA
	below LV	3 mA
	Fail Safe	1 mA
Function	Pointer	Signal
		SJ3,5-S1N
MAX	above LV	1 mA
	below LV	3 mA
	Fail Safe	1 mA

Note: LV = Limit value

COMPLIANCE WITH IEC 61508

RAMC with local indicator and fail safe limit switches (-T[]NNN /K6 ... /K10):

Suitable for application in safety functions up to and including SIL2.

RAMC with local indicator and standard limit switches (-T[]NNN /K1 ... /K3):

Suitable for application in safety functions up to and including SIL2.

RAMC with 4-20mA output (-E[]424 and -H[]424):

Suitable for application in safety functions up to and including SIL1, but only with activated Float Blocking Indication.

Reliability data available on request in FMEDA report.

COMPLIANCE WITH ISO 13849

For Safety Metrics acc. to ISO 13849-2 please refer to the FMEDA report.

METROLOGICAL REGULATION IN CIS (GOST)

RAMC has "Pattern Approval Certificate of Measuring Instruments" and is registered as a measuring instrument in Russia, Kazakhstan, Uzbekistan, Belarus and Ukraine. The calibration laboratory of Rota Yokogawa is approved by Federal Agency on Technical Regulating and Metrology in Russia and other Metrological Organizations in CIS countries to issue primary calibration confirmations for RAMC, option /QR[.]

Furthermore RAMC is RTN (GGTN) approved for installation in hazardous areas.

For export to CIS countries please contact your Yokogawa representative.

HAZARDOUS AREA SPECIFICATIONS

Overview hazardous area certified instruments:

Location	Europe				Global			USA	Canada	India	Korea	China	
Certificate	ATEX				IECEX			FM	FM	PESO	KOSHA	NEPSI	
Electronic transmitter (WT-MAG)													
Protection	ia	ic	nL	ia/tb	ia	ic	ia/tb	IS/NI	IS/NI	ia	ia	-	
Option	/KS1	/KS3	/KN1	/KS2	/ES1	/ES3	/ES2	/FS1	/CS1	/KS1	/ES1	-	
Comments		*2)		*1)		*2)	*1)	*3)	*3)	*4)		-	
See page	6	6	6	9	6	6	9	6	6	6	6	-	
Limit switches													
Protection	ia/iaD	ic	nL	ia/tb	ia	-	ia/tb	IS/NI	IS/NI	-	-	ia	-
Option	/KS1	/KS3	/KN1	/KS2	/ES1	-	/ES2	/FS1	/CS1	-	-	/NS1	-
Comments		*2)		*1)		-	*1)	*5)	*6)	-	-		-
See page	7	7	7	9	7	-	9	7	7	-	-	7	-
RAMC indicator													
Protection	d/tb		-		d/tb		-		-	d	d/tb	ia	d/DIP
Option	/KF1		-		/EF1		-		-	/KF1	/EF1	/NS1	/NF1
Comments	*7)		-		*7)		-		-	*4)			*7)
See page	8		-		8		-		-	8	8	6	8
Power supplies for intrinsic safe components (see page 7)													
Option /UT	yes				yes			yes	yes	no	no	yes	
Option /W1A,B	yes				yes			yes	yes	yes	yes	no	
Option /W2A,B	yes				yes			yes	yes	yes	yes	no	
Option /W4A,B	yes				yes			yes	yes	yes	yes	yes	
Option /W2E,F	yes				yes			no	no	no	no	no	
Option /W4E,F	yes				yes			no	no	no	no	yes	
Notation	IS = intrinsic safe; NI = non incensive; DIP = dust ignition proof												
Comment *1)	Dust proof by RAMC housing												
Comment *2)	For use in category 3G												
Comment *3)	Same certification for USA and Canada												
Comment *4)	PESO certificate available from Yokogawa Sales Office												
Comment *5)	Only for USA; power supply free selectable												
Comment *6)	For USA and Canada; power supply must be option /WxA or /WxB (x=1 or 2 or 4)												
Comment *7)	Only with housing 91												

ELECTRONIC TRANSMITTER**Attention :**

The maximum ambient temperature of the transmitter or of the limit switches according to the temperature class may not be exceeded because of heat transmission from the medium.

Table 6 Entity parameters of electronic transmitter

	Ui [V]	Ii [mA]	Pi [W]	C i[nF]	Li [mH]	Tamax [°C]
KS1/2/3	30	101	1.4	4.16	0.15	70
ES1/2/3	30	101	1.4	4.16	0.15	70
KN1	30	152	1.4	4.16	0.15	70
FS1/CS1	30	100	1.4	40	0.15	70
NS1	30	101	1.4	4.16	0.15	70

Intrinsically safe electronic transmitter 4 - 20mA (with/without HART-communication) with ATEX-certification (option /KS1) :**Certificate :**

PTB 12ATEX 2003

Output signal :

4–20 mA (2- wire unit, 3- wire unit) ; 0-20mA (3- wire unit)

Explosion proof :

Ex ia IIC T6 Gb; group II ; category 2G

Entity parameter :

see table 6

Intrinsically safe electronic transmitter Profibus PA - communication with ATEX- certification (option /KS1) :**Certificate:**

PTB 96ATEX 2160X

Output signal :

Profibus PA

Explosion proof :

Ex ia IIB/IIC T4; group II; category 2G

Table 7 Entity parameters

	IIC	IIB	FISCO IIB/IIC
Ui	24V	17.5V	acc. IEC 60079-27
Ii	250mA	280mA	
Li	negligible small	negligible small	
Ci	negligible small	negligible small	

Electronic transmitter 4 - 20mA (with/without HART-communication) type “n” (non incandive) acc. EN 60079-15 for category 3 (option /KN1) :**Output signal :**

4–20 mA (2- wire unit, 3- wire unit) ; 0-20mA (3- wire unit)

Explosion proof :

Ex nL IIC T6 protection „nL”; group II ; category 3G

Dust proof :

Ex II 3D; group II ; category 3D
Max. surface temperature : 80°C

Entity parameter :

see table 6

Intrinsically safe electronic transmitter 4 - 20mA (with/without HART-communication) with IECEx- certification (option /ES1) :**Certificate :**

IECEx PTB 12.0020

Output signal :

4–20 mA (2- wire unit, 3- wire unit) ; 0-20mA (3- wire unit)

Explosion proof :

Ex ia IIC T6 Gb; group II ; category 2G

Entity parameter :

see table 6

Intrinsically safe electronic transmitter 4 - 20mA (with/without HART-communication) with ATEX- or IECEx- certification for use in category 3G (option /KS3 or /ES3) :**Output signal :**

4–20 mA (2- wire unit, 3- wire unit) ; 0-20mA (3- wire unit)

Explosion proof :

Ex ic IIC T6 Gc; group II ; category 3G

Entity parameter :

see table 6

Intrinsically safe / non incandive electronic transmitter with FM - certification (USA + Canada) (USA: option /FS1; Canada: option /CS1) :**Certificate :**

No. : 3027471

Output signal :

4–20 mA (2-wire unit)

Explosion proof :

Intrinsic safe Cl. I, Div. 1, GP. A, B, C, D T6
Intrinsic safe Cl. 1, Zone 0, AEx ia IIC T6
Non incandive Cl. I, Div. 2, GP. A, B, C, D T6

Entity parameter of electronic transmitter :

see table 6

Intrinsically safe electronic transmitter with KOSHA- certification (Korea)

Option /ES1 must be selected.

Same data as for IECEx certification.

Intrinsically safe electronic transmitter with PESO- certification (India)

Option /KS1 must be selected. PESO- certificate is available at your Yokogawa Sales Office.

Intrinsically safe RAMC with NEPSI- certification (China) (option /NS1) :**Certificate :**

GYJ0101551

Output signal :

4–20 mA (2- wire unit, 3- wire unit) ; 0-20mA (3- wire unit)

Explosion proof :

Ex ia IIC T6

Max. Tamb. :

70°C

Entity parameter of electronic transmitter :

see table 6

Limit switches :

option /K1 to /K10

Entity parameter of limit switches :

see certificate NEPSI GYJ06542X

LIMIT SWITCHES

Intrinsically safe and dust proof limit switches with ATEX-certification (option /K1 ... /K10 with /KS1) :

Certificate:

- PTB 99 ATEX 2219X (SC3.5-NO) (/K1 ... /K3)
- PTB 00 ATEX 2049X (SJ 3.5-S.N) (/K6 ... /K10)
- ZELM 03 ATEX 0128X (for dust proof)

Explosion proof :

Ex ia IIC T6, group II category 2G

Dust proof (only indicator "T") :

Ex iaD 20 T 108 °C, group II category 1D
Max. surface temperature : T108°C

Entity parameter :

see certificate of conformity

Limit switches for category 3 (option /K1 ... /K10 with /KN1):

Explosion proof :

EEx nL IIC T6 X protection „nL“; group II ; category 3G

Entity parameter :

see specification of SC3,5-N0 Blue (P&F)* (/K1 ... /K3)
see specification of SJ3,5-SN (P&F)* (/K6 ... /K10)
see specification of SJ3,5-S1N (P&F)* (/K6 ... /K10)
* P&F = Pepperl & Fuchs

Intrinsically safe limit switches with ATEX-certification for use in category 3G (option /K1 ... /K10 with /KS3) :

Explosion proof :

Ex ic IIC T6 X, group II category 3G

Entity parameter :

see specification of SC3,5-N0 Blue (P&F)* (/K1 ... /K3)
see specification of SJ3,5-SN (P&F)* (/K6 ... /K10)

Intrinsically safe limit switches with IECEx-certification (option /K1 ... /K10 with /ES1) :

Certificate:

- IECEx PTB11.0091 (SC3.5-NO) (/K1 ... /K3)
- IECEx PTB11.0092 (SJ 3.5-S.N) (/K6 ... /K10)

Explosion proof :

Ex ia IIC T6 Gb

Entity parameter :

see certificate of conformity

Intrinsically safe / non incendive limit switches with FM- certification (USA) (option /K1 ... /K10 with /FS1) :

Explosion proof :

IS : Cl. I, Div. 1, Gp. ABCD, T6, Ta = 60°C,
NI : Cl. I, Div. 2, Gp. ABCD, T5, Ta = 50°C
Cl. II, Div. 1, Gp. EFG
Cl. III, Div. 1

Entity parameter :

see FM-control drawing 116-0165 for IS
see FM-control drawing 116-0155 for NI

Intrinsically safe limit switches with CSA- certification (Canada) (option /K1 ... /K3 with /CS1) :

Explosion proof :

Cl. I, II, III, Div. 1, Gp. ABCDEFG

Entity parameter :

see drawing 116-0047

Only in combination with option /WxA or /WxB.

Intrinsically safe limit switches with NEPSI-certification (China) (option /K1 .. /K10 with /NS1):

Certificate :

GYJ11.1505X (option /K1.../K3)
GYJ11.1507X (option /K6.../K10)

Explosion proof :

Ex ia IIC T1 ... T6

Entity parameter :

see certificate

POWER SUPPLIES FOR INTRINSIC SAFE COMPONENTS

Power Supply for the intrinsically safe electronic transmitter (option /UT)

Type :

Power supply with galvanically separated input and output
- RN221N-B1, HART- compatible

Certificate :

ATEX: PTB 00 ATEX 2018
IECEx: PTB06.0089
FM: 3007835, Control Drawing 02 02 00 111
CSA: 1067708, Control Drawing 02 02 00 112
NEPSI: GYJ06495

Supply voltage :

20 ... 250 V DC / AC 50/60 Hz

Maximum load impedance :

700 Ω

Output signal :

4 - 20 mA

Control circuit :

Intrinsically safe [Ex ia] IIC; group II ; category (1)GD

Entity parameters :

see fig. 4

Power supply for intrinsically safe limit switches (option W__):

Type :

acc. DIN EN 50227 (NAMUR)
- KFA5-SR2-Ex*-W (115 V AC)
- KFA6-SR2-Ex*-W (230 V AC)
- KFD2-SR2-Ex*-W (24 V DC)
- KHA6-SH-Ex1 (115/230 V AC), Fail Safe, 1 channel
- KFD2-SH-Ex1 (24 V DC), Fail Safe, 1 channel

Certificates :

- KFA5-SR2-Ex*-W:	ATEX	: PTB 00 ATEX 2081
	CSA	: 1029981 (LR 36087-19)
	FM	: ID 3011578
	IECEx	: PTB11.0031
	PESO	
	KOSHA	: 2009-BO-0157
- KFA6-SR2-Ex*-W:	ATEX	: PTB 00 ATEX 2081
	CSA	: 1029981 (LR 36087-19)
	FM	: ID 3011578
	IECEx	: PTB11.0031
	PESO	
	KOSHA	: 2009-BO-0157
- KHA6-SH-Ex1:	ATEX	: PTB 00 ATEX 2043
- KFD2-SR2-Ex*-W:	ATEX	: PTB 00 ATEX 2080
	CSA	: 1029981 (LR 36087-19)
	FM	: ID 3011578
	IECEx	: PTB11.0034
	PESO	
	KOSHA	: 2009-BO-0157
	NEPSI	: GYJ12.1081
- KFD2-SH-Ex1:	ATEX	: PTB 00 ATEX 2042
	NEPSI	: GYJ091350

Control circuit (ATEX) :

[Ex ia] IIC; group II ; category (1)GD

Entity parameter :

see fig. 4 (ATEX) and certificate

FLAME PROOF AND DUST PROOF RAMC**Flame proof and dust proof RAMC with ATEX-certificate (option /KF1):****Certificate :**

IBExU 05 ATEX 1086

Flame proof :

Ex d IIC T1 ... T6 Gb ; group II ; category 2G

Dust proof :

Ex tb IIIC TX Db IP6X; group III ; category 2D

Max. surface temperature TX :corresp. process temperature

Housing :

Painted aluminium casting, type 91

Output signal (with electronic transmitter -E, -H) :

4–20 mA (2- wire unit, 3- wire unit) ; 0-20 mA (3- wire unit)

Power supply (with electronic transmitter -E, -H) :

2- or 3- wire unit

Limit switches :

Options /K1 to /K10 possible

Ambient temperature :

-20 °C to 60 °C

Minimum process temperature :

-20°C

Threads for cable glands :

- M20x1.5 (standard)

- 1/2" NPT (option /A5)

Temperature classification :**Table 8**

see table 8

Flame proof and dust proof RAMC with IECEx-certificate (option /EF1):**Certificate :**

IECEx IBE12.0007

Flame proof :

Ex d IIC T1 ... T6 Gb ; group II ; category 2G

Dust proof :

Ex tb IIIC TX Db IP6X; group III ; category 2D

Max. surface temperature TX :corresp. process temperature

Housing :

Painted aluminium casting, type 91

Output signal (with electronic transmitter --E, -H) :

4–20 mA (2- wire unit, 3- wire unit) ; 0-20 mA (3- wire unit)

Power supply (with electronic transmitter -E, -H) :

2- or 3- wire unit

Limit switches :

Options /K1 to /K10 possible

Ambient temperature :

-20 °C to 60 °C

Minimum process temperature :

-20°C

Threads for cable glands :

- M20x1.5 (standard)

- 1/2" NPT (option /A5)

Temperature classification :**Table 8**

see table 8

Flame proof and dust proof RAMC with NEPSI-certificate (China) (option /NF1) :**Certificate :**

GYJ071430

Flame proof :

Ex d IIC T6

Dust proof :

DIP A20 TA T1 - T6 IP67

Max. surface temperature TA: corresponding process temperature

Housing :

Painted aluminium casting type 91

Output signal (with electronic transmitter -E or -H) :

4–20 mA (2- wire unit, 3- wire unit) ; 0-20 mA (3- wire unit)

Power supply (with electronic transmitter -E or -H) :

2- or 3- wire unit

Limit switches :

Options /K1 to /K10 possible

Ambient temperature :

-20 °C to 60 °C

-20 °C to 55 °C (for use in zone 20)

Minimum process temperature :

-20°C

Threads for cable glands :

- M16x1.5 (standard)

- 1/2" NPT (option /A5)

Temperature classification :**Table 8**

Temp. class	Max. Process temperature		
	No extension	On Extension	On extension with insulation
T6	85°C	85°C	85°C
T5	100°C	100°C	100°C
T4	120°C	135°C	135°C
T3	120°C	200°C	200°C
T2	120°C	300°C	300°C
T1	120°C	370°C	350°C

Flame proof and dust proof RAMC with PESO-certificate (India) :

Option /KF1 must be selected. PESO- certificate is available at your Yokogawa Sales Office.

Flame proof and dust proof RAMC with KOSHA-certificate (Korea):

Same data as IECEx- certified type (/EF1).

INTRINSIC SAFE COMPONENTS WITH DUST-PROOF

ATEX- certified intrinsically safe electronic transmitter 4 - 20mA, with/without limit switches with dust proof RAMC (option /KS2):

Certificate :

PTB 12 ATEX2003 (Intrinsic safe electronic transmitter)
PTB 99 ATEX2219X (Intrinsic safe limit switch SC3.5-N0)
PTB 00 ATEX2049X (Intrinsic safe limit switch SJ 3.5-S.N)
IBExU 05 ATEX1086 (Dust proof)

Output signal electronic transmitter:

4–20 mA (2-wire unit, 3-wire unit) ; 0-20mA (3-wire unit)

Explosion proof :

Ex ia IIC T6 Gb; group II ; category 2G

Dust proof :

Ex tb IIIC TX Db IP6X; group III ; category 2D
Max. surface temperature TX : corresponding process temperature

Entity parameter :

see table 6 for electronic transmitter (/KS1)
see certificates for limit switches

Housing :

Painted aluminium casting, type 91

Ambient temperature :

-20 °C to 60 °C

Minimum process temperature :

-20°C

Threads for cable glands :

- M20x1.5 (standard)
- ½" NPT (option /A5)

IECEx- certified intrinsically safe electronic transmitter 4 - 20mA, with/without limit switches with dust proof RAMC (option /ES2):

Certificate :

IECEx PTB12.0020 (Intrinsic safe electronic transmitter)
IECEx PTB11.0091 (Intrinsic safe limit switch SC3.5-N0)
IECEx PTB11.0092 (Intrinsic safe limit switch SJ 3.5-S.N)
IECEx IBE12.0007 (Dust proof)

Output signal electronic transmitter:

4–20 mA (2-wire unit, 3-wire unit) ; 0-20mA (3-wire unit)

Explosion proof :

Ex ia IIC T6 Gb; group II ; category 2G

Dust proof :

Ex tb IIIC TX Db IP6X; group II ; category 2D
Max. surface temperature TX : corresponding process temperature

Entity parameter :

see table 6 for electronic transmitter (/KS1)
see certificates for limit switches

Housing :

Painted aluminium casting, type 91

Ambient temperature :

-20 °C to 60 °C

Minimum process temperature :

-20°C

Threads for cable glands :

- M20x1.5 (standard)
- ½" NPT (option /A5)

INSTALLATION

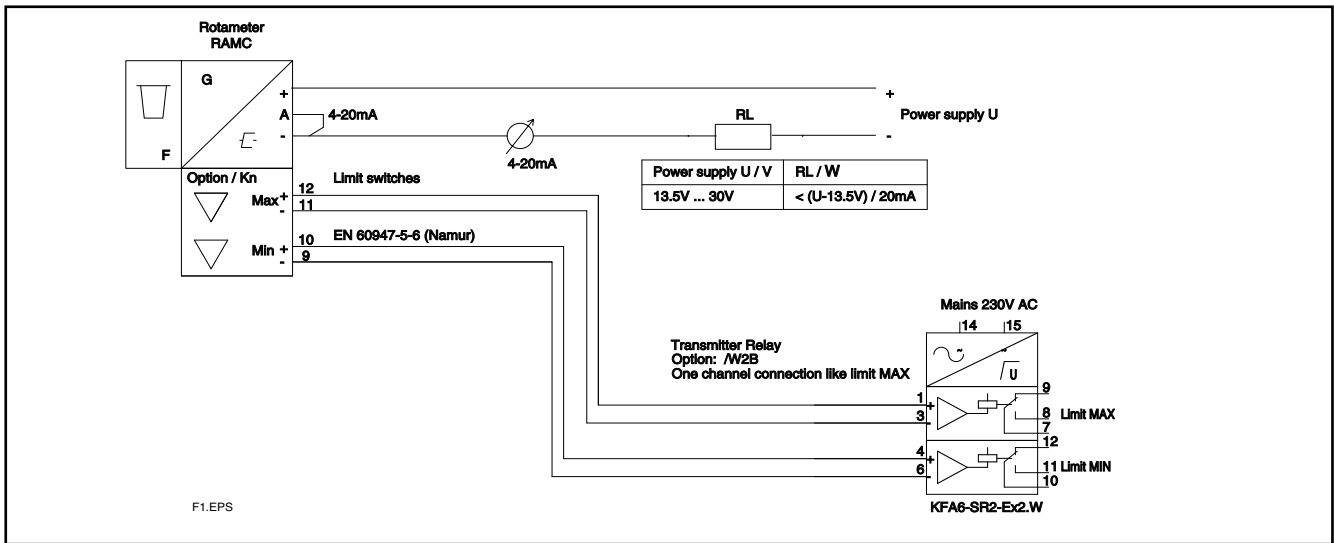

fig. 1 RAMC 2- wire unit with inductive limit switches and transmitter relay

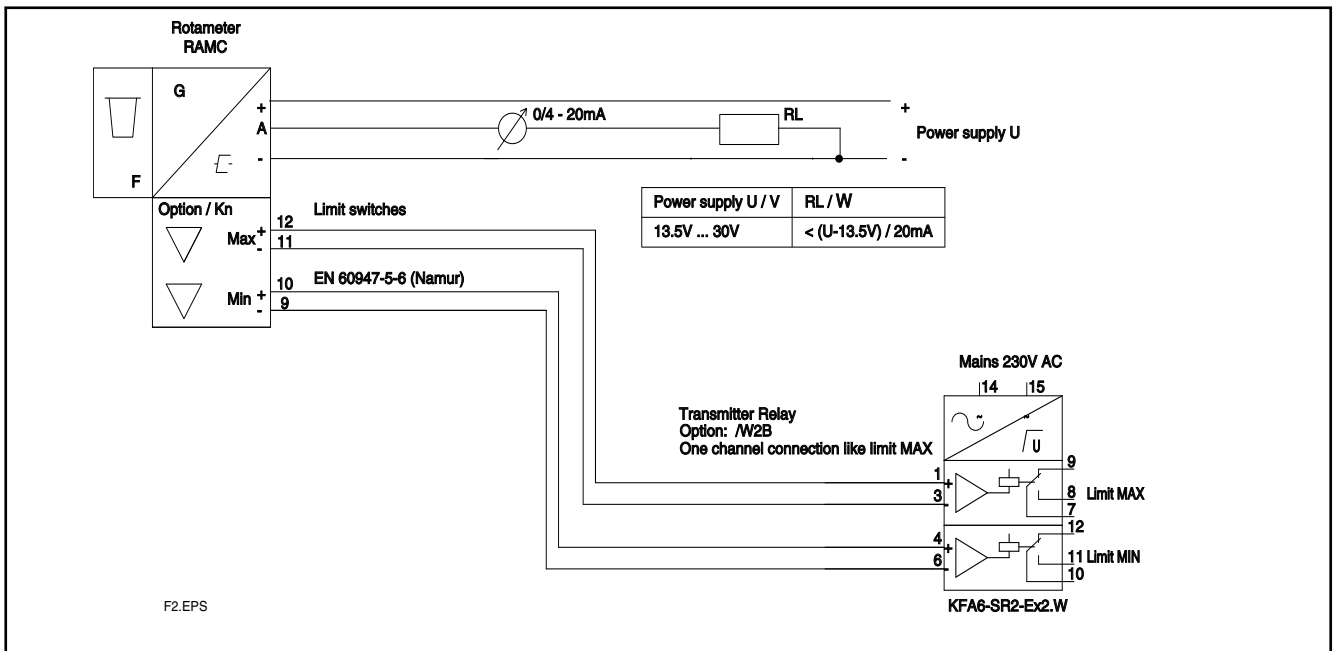

fig. 2 RAMC 3- wire unit with inductive limit switches and transmitter relay

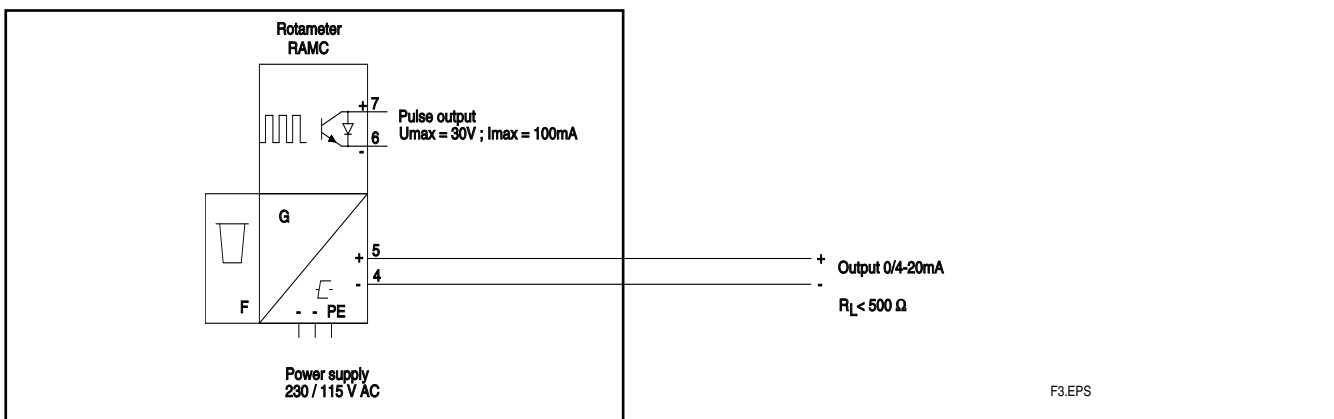

fig. 3 RAMC 4-wire unit with pulse output

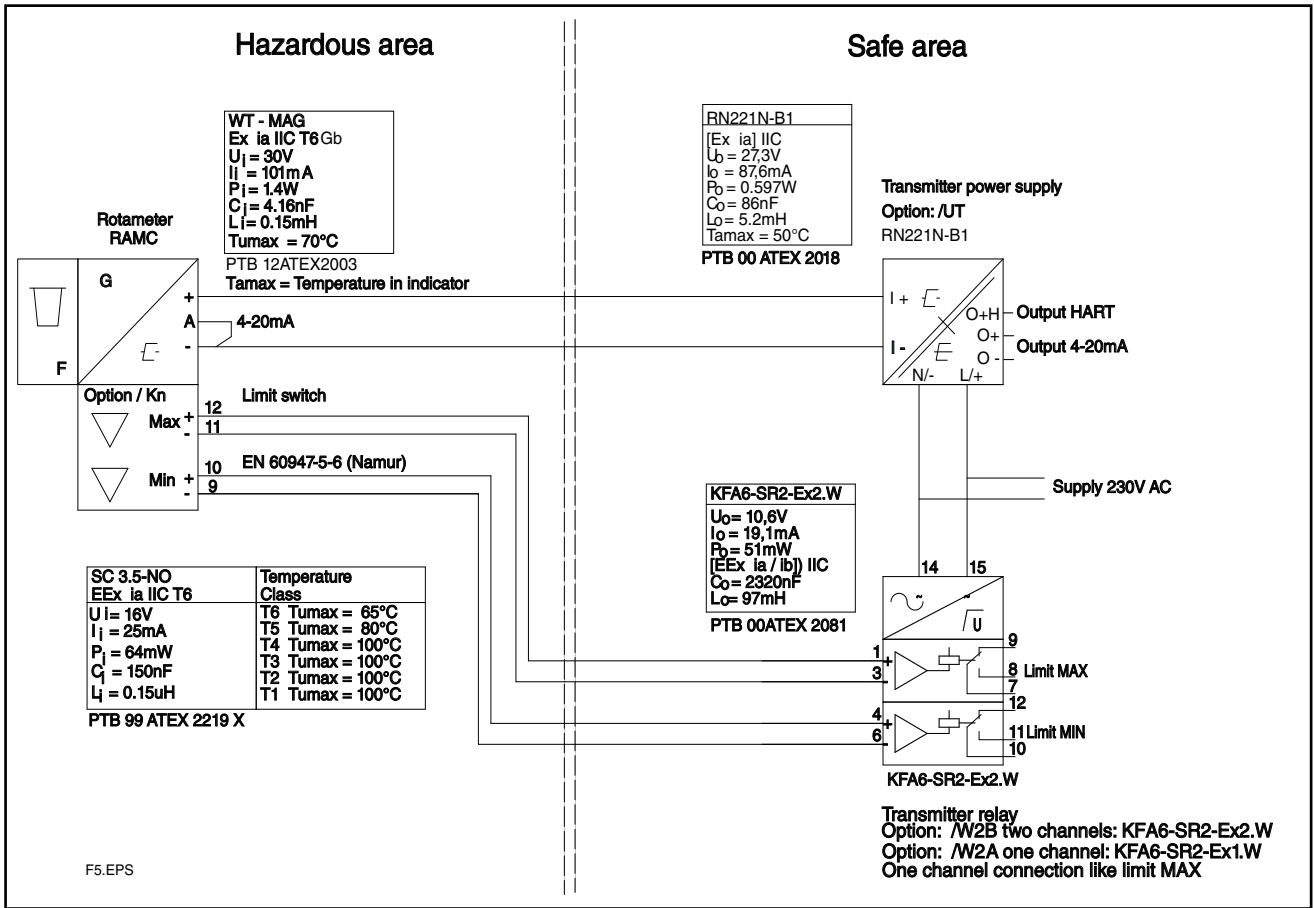

fig. 4 Intrinsic safe version according ATEX (option /KS1 or /KS2) : RAMC 2- wire unit with power supply, inductive limit switches and transmitter relay

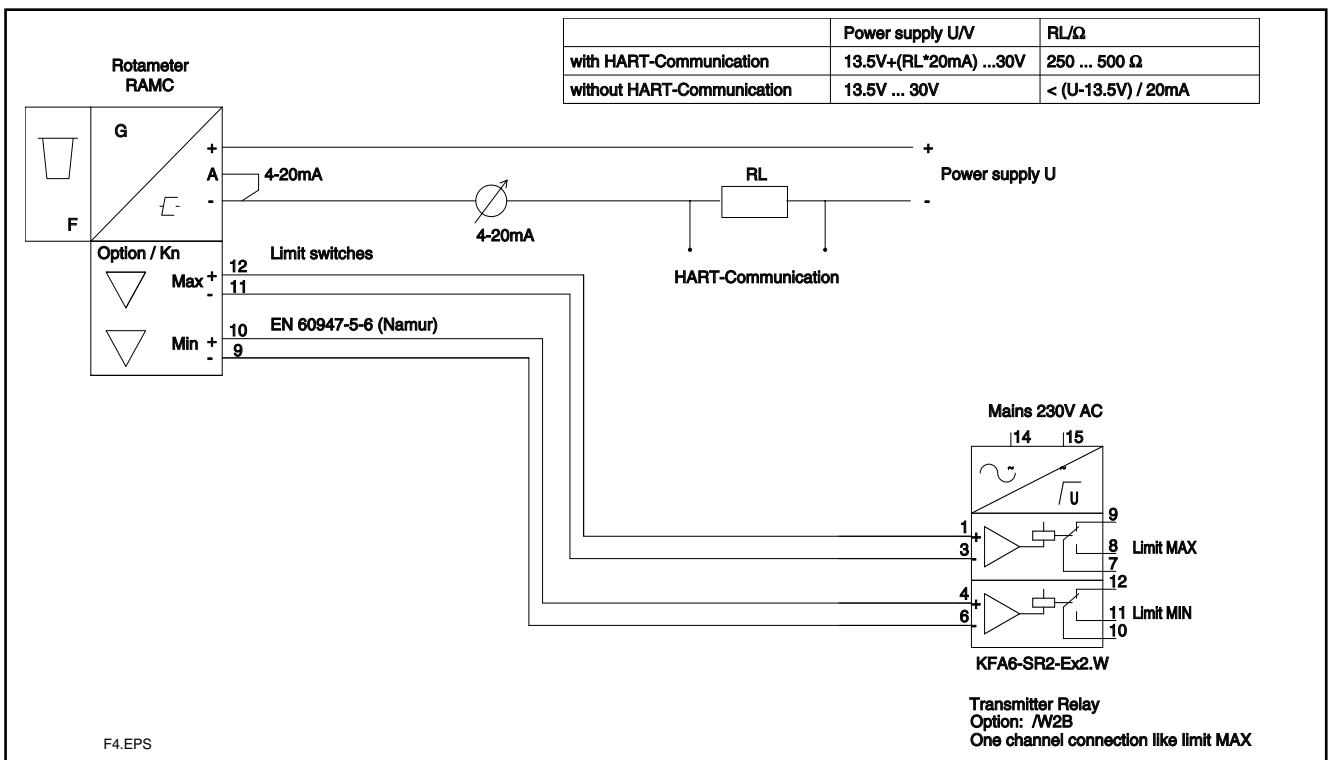

fig. 5 RAMC 2- wire unit with HART-communication, inductive limit switches and transmitter relay

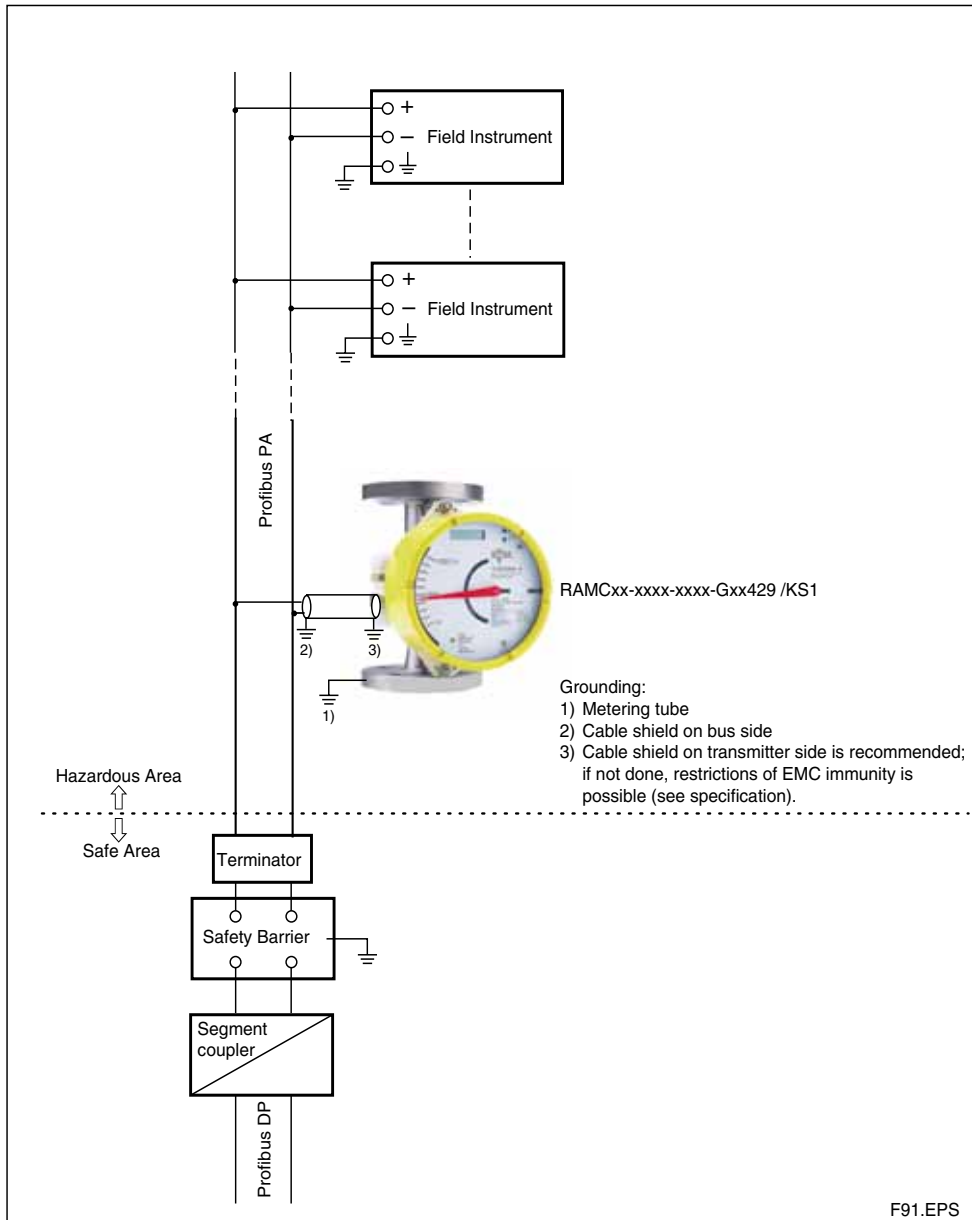

fig. 6 RAMC Profibus PA - communication

Planning and Installation Hints

- The user is responsible for the use of our flow meters regarding suitability and use as agreed.
- The actual operation pressure must be lower as the specified pressure limits of the Rotameter.
- Make sure that the wetted parts are resistant against the process medium.
- Ambient- and process temperature must be lower than the specified maximum values.
- If dirt accumulation is to be expected, we recommend to install a bypass pipe
- To avoid float bouncing in case of gas application notice the recommendations of VDI/VDE 3513 Sheet 3.
- To avoid mutual magnetic influence in case of parallel design of several Rotameters take care that the distance between the tube middle axes is not less than 300 mm. The distance to other ferric materials should not be less than 250 mm.
- Avoid static magnetic fields next to the Rotameter.

MODEL SPECIFICATIONS

Model	Suffix code	Description	Restrictions
RAMC01 RAMC23 RAMC02		Size DN 15 (½ inch) Size DN 20 (¾ inch) Size DN 25 (1 inch)	for D4, D6, A1, A2, A3, T4, R4, T6, G6 for D4, D6, A1, A2, A3, T4, R4, T6, G6 for D4, D6, A1, A2, A3, S2, S4, S5, T4, R4, T6, G6
RAMC03 RAMC04 RAMC05 RAMC06		Size DN 32 (1¼ inch) Size DN 40 (1½ inch) Size DN 50 (2 inch) Size DN 65 (2½ inch)	for D4, D6, A1, A2, A3, S4, T6, G6 for D4, D6, A1, A2, A3, S4, S5, T6, G6 for D4, D5, D6, A1, A2, A3, S2, S4, T4, R4 for D4, D5, A1, A2, A3, S2, S4, T4, R4, T6, G6
RAMC08 RAMC09 RAMC10 RAMC12 RAMC15 RAMCNN		Size DN 80 (3 inch) 3½ inch Size DN 100 (4 inch) Size DN 125 (5 inch) Size DN 150 (6 inch) Without measuring tube	for D4, D5, A1, A2, A3, S2, S4 for A1, A2 for D2, D4, A1, A2, S4, S4 for D2, A1, A2, S2 for D2, A1, A2
Process connection	-D2 -D4 -D5 -D6 -A1 -A2 -A3 -T6 -G6 -R4 -S2 -S4 -T4 -S5 -NN	EN flange PN 16, process connection dimension + facing acc. EN 1092-2 Form B1 EN flange PN 40, process connection dimension + facing acc. EN 1092-2 Form B1 EN flange PN 63, process connection dimension + facing acc. EN 1092-2 Form B1 EN flange PN 100, process connection dimension + facing acc. EN 1092-2 Form B1 ASME flange class 150, process connection dimension + facing acc. ASME B 16.5 ASME flange class 300, process connection dimension + facing acc. ASME B 16.5 ASME flange class 600, process connection dimension + facing acc. ASME B 16.5 NPT PN 40 female thread G PN 40 female thread Rp removable female thread Thread acc. DIN 11851 Tri- clamp PN 10, PN16 acc. DIN 32676 NPT removable female thread Flange Rosita PN 10 Without process connection	
Material of wetted parts	SS PF NN	Stainless steel Teflon lining Without wetted parts	Only with RAMCNN
Cone / Float	-nnnn -NNNN	See tables 10 ... 12 Without measuring tube / without float	Only with RAMCNN
Indicator / Transmitter	-T -E -G -H -N	Indicator local Indicator electronic Indicator electronic with Profibus PA Indicator electronic with HART Without indicator	Only with output 429 Only with output 424 Only with housing NN
Housing / Type	90 91 NN	Housing round blanc; SS Housing round yellow; Al Without housing	Only with indicator N
Power supply / Output	240 244 140 144 430 434 424 429 NNN	230 V AC ; 4- wire; 0-20 mA 230 V AC ; 4- wire; 4-20 mA 115 V AC ; 4- wire; 0-20 mA 115 V AC ; 4- wire; 4-20 mA 24 V DC; 3- wire; 0-20 mA 24 V DC; 3- wire; 4-20 mA 24 V DC; 2- wire; 4-20 mA Profibus PA; 9 ... 32 V DC Without power supply	Only with indicator E; not with limit switches Only with indicator E; not with limit switches Only with indicator E; not with limit switches Only with indicator E; not with limit switches Only with indicator E Only with indicator E Only with indicator E, H Only with indicator G; not with limit switches Only with indicator T or N

OPTIONS

Options	Code	Description	Restriction
Indicator	/A5 /A12 /A13 /A14 /A16 /A17 /A18 /A20 /A21 /A22 /A23 /A25 /A26	Thread for cable gland ASME ½" NPT female US- engineering units Thread for cable gland ISO M20 x 1,5 female Housing color green Indicator on 95 mm extension Housing color green Housing color yellow Scale for type T66 Scale and EEPROM for type E66, H66, G66 Scale for type T90, T91 Scale and EEPROM for type E90, H90, G90, E91, H91, G91 Pressure balance element Indicator for -40°C ambient temperature	Not with /A13 Only for indicator E, H Not with /A5, /KF1, /NF1, /KS2 Only for housing 91 Only for housing 90 + 91 Only for housing 90 Only for housing 90 Not with hazardous approval type; not with indicator Not with hazardous approval type not with indicator Not with hazardous approval type; not with indicator Not with hazardous approval type; not with indicator Not with /KS2, /ES2, /KF1, /EF1, /NF1 and housing 91 with /A5 or /A13 Not with /K1, /K2, /K3, /K9, /K10, /KF1, /EF1, /NF1, /KS2, /ES2, /FS1, /CS1, /NS1, /SS†, power supply 14n + 24n.
Marking	/B0 /B1 /BT1 /BT2 /B4 /B8 /B10 /BG /BD	Tag plate (SS) on flange and customer specified tag number on scale Tag plate (SS) fixed by wire and customer specified tag number on scale Software tag HART 5 Software tag, bus address for Profibus PA Neutral version Customer provided marking on label Percent scale With customer specified tag number on scale Dual scale	Plate 9 x 40 mm; max. 45 digits Plate 9 x 40 mm; max. 45 digits 8 digits for tag; 22 digits for long tag; only indicator H 32 digits for tag; 4 digits bus address; only indicator G Not with hazardous approval type Max. 45 digits Adjustment only for the first mentioned fluid
Limit switches	/K1 /K2 /K3 /K6 /K7 /K8 /K9 /K10	MIN- contact MAX- contact MIN-MAX- contact, MIN-MIN- contact, MAX-MAX- contact MIN- contact "Fail safe" version MAX- contact "Fail safe" version MIN-MAX- contact "Fail safe" version MIN-MIN- contact "Fail safe" version MAX-MAX- contact "Fail safe" version	Not for power supply 14n + 24n Not for power supply 14n + 24n Not for power supply 14n + 24n Not for power supply 14n + 24n Not for power supply 14n + 24n Not for power supply 14n + 24n Not for power supply 14n + 24n Not for power supply 14n + 24n
Pulse output	/CP	Pulse output isolated	Only for power supply 14n + 24n
Flange Facing	/D10 /D11	EN raised face B2 : Ra 0.8 - 3.2 EN groove Form D	Only for EN- flanges (D2, D4) Only for EN- flanges (D2, D4)
Test and certificates	/H1 /H3 /P2 /P3 /P6 /PM3 /PP /PT /P9 /WP	Oil + fat free for wetted surfaces acc. ASTM G93-03 level C Certificate pure water application Certificate of compliance with the order acc. EN 10204: 2004 -2.1 As /P2 + Test report acc. EN 10204: 2004 -2.2 Material certificate acc. EN 10204: 2004 -3.1 PAMI test (3 points: Process connection inlet, measuring tube, process connection outlet) Pressure test report measuring system Flow table for conversion Dye penetration test of flange welding acc. to EN 571 WPS acc. DIN EN ISO 15609-1 (Welding Procedure Specification) WPQR acc. DIN EN ISO 15614-1 (Welder Performance Qualification Record) WQC acc. DIN EN 1418 (Welder Qualification Certificate), robot welding WQC acc. DIN EN 287-1 (Welder Qualification Certificate), manual welding (SS) WQC acc. DIN EN ISO 6906-4 (Welder Qualification Certificate), manual welding (nickel alloy)	Only for metallic pressurized parts Only for SS material of wetted parts Not for connection RAMC01-T6SS-[]S0-..., RAMC01-G6SS-[]S0-...; not for /Tx Not for connection RAMC01-T6SS-[]S0-..., RAMC01-G6SS-[]S0-...; not for /Tx
Damping	/SD	Float damping system	Only for SS; not for cone 81 + 82; only for gas application
Flange protection	/QK	Flange covers (EN flange)	Only for EN- flanges (D2, D4)
Delivery to Korea	/KC	With KC-mark for Korea	

Options	Code	Description	Restriction
Hazardous area approvals	/KS1	ATEX intrinsically safe "ia"	Only for power supply 424, 430, 434, 429; for indicator T only with limit switches
	/KS2	ATEX intrinsically safe "ia" + dust proof "tb"	Only for power supply 424, 430, 434; for indicator T only with limit switches; only for housing 91
	/KS3	ATEX intrinsically safe "ic" for use in category 3G	Only for power supply 424, 430, 434; for indicator T only with limit switches
	/KN1	ATEX non incendive "nL" for use in category 3G / 3D	Only for power supply 424, 430, 434; for indicator T only with limit switches
	/ES1	IECEX intrinsically safe "ia"	Only for power supply 424, 430, 434; for indicator T only with limit switches
	/ES2	IECEX intrinsically safe "ia" + dust proof "tb"	Only for power supply 424, 430, 434; for indicator T only with limit switches; only for housing 91
	/ES3	IECEX intrinsically safe "ic"	Only for power supply 424, 430, 434; not with limit switches
	/FS1	FM intrinsically safe / non incendive electr. transmitter (USA)	Only for power supply 424 (electronic transmitter); for indicator T only with limit switches
	/CS1	FM intrinsically safe / non incendive limit switches (USA)	Only for power supply 424 (electronic transmitter); for indicator T only with limit switches; limit switches only /K1, /K2, /K3, only in combination with power supply /WxA or /WxB
	/NS1	NEPSI intrinsically safe approval (China)	Only for power supply 424, 430, 434; not for indicator S; for indicator T only with limit switches; only housing 90
	/KF1	ATEX flame proof "d" / dust proof "tb"	Only for power supply 424, 430, 434; for indicator T only with limit switches; only with housing 91
	/EF1	IECEX flame proof "d" / dust proof "tb"	Only for power supply 424, 430, 434; for indicator T only with limit switches; only with housing 91
/NF1	NEPSI flame proof "d" / dust proof approval (China)	Only for power supply 424, 430, 434; for indicator T only with limit switches; only for housing 91	
Gost approval	/QR1	Primary Calibration and Test Confirmation valid in Russia	See page 4
	/QR2	Primary Calibration and Test Confirmation valid in Kazakhstan	See page 4
	/QR3	Primary Calibration and Test Confirmation valid in Uzbekistan	See page 4
Heat tracing	/T1	Heat tracing, process connection G ¼" PN 40 female thread	Only for SS material of wetted parts
	/T2	Heat tracing, process connection DN 15 PN 40	Only for SS material of wetted parts
	/T3	Heat tracing, process connection DN 25 PN 40	Only for SS material of wetted parts
	/T4	Heat tracing, process connection ASME ½" 150#	Only for SS material of wetted parts
	/T5	Heat tracing, process connection ASME 1" 150#	Only for SS material of wetted parts
	/T6	Heat tracing, process connection ¼" PN 40 NPT female thread	Only for SS material of wetted parts
Power supply for electronic transmitter	/UT	RN221N-B1, 20 ... 250V DC/AC, Ex i, Hart compatible	Only for indicator E, H, J
Power supply for limit switches (transmitter relay)	/W1A	KFA5-SR2-Ex1.W / 115 V AC, 1 channel	Only for limit switches /K1, /K2, /K3
	/W1B	KFA5-SR2-Ex2.W / 115 V AC, 2 channel	Only for limit switches /K1, /K2, /K3
	/W2A	KFA6-SR2-Ex1.W / 230 V AC, 1 channel	Only for limit switches /K1, /K2, /K3
	/W2B	KFA6-SR2-Ex2.W / 230 V AC, 2 channel	Only for limit switches /K1, /K2, /K3
	/W2E	KHA6-SH-Ex1 / 115/230 V AC, 1 channel, Fail Safe	Only for limit switches /K6 to /K7
	/W2F	2x KHA6-SH-Ex1 / 115/230 V AC, 1 channel, Fail Safe	Only for limit switches /K8 to /K10
	/W4A	KFD2-SR2-Ex1.W / 24 V DC, 1 channel	Only for limit switches /K1, /K2, /K3
	/W4B	KFD2-SR2-Ex2.W / 24 V DC, 2 channel	Only for limit switches /K1, /K2, /K3
	/W4E	KFD2-SH-Ex1 / 24 V DC, 1 channel, Fail Safe	Only for limit switches /K6 to /K7
/W4F	2x KFD2-SH-Ex1 / 24 V DC, 1 channel, Fail Safe	Only for limit switches /K8 to /K10	
Instruction manuals	/IE _n	Quantity of instruction manuals in English	n = 1 to 9 selectable *)
	/ID _n	Quantity of instruction manuals in German	n = 1 to 9 selectable *)
	/IF _n	Quantity of instruction manuals in French	n = 1 to 9 selectable *)
Special order	/Z	Special design must be specified separately	

*) if no instruction manual is selected, only a DVD with instruction manuals is shipped with the flowmeter

Specify the following when ordering :

- 1) Model, suffix code and option code
- 2) Fluid name ; Process temperature ; Process density ; Process pressure ; Process viscosity
- 3) For gases : Condition of the scale (st. or actual)
- 4) Options : Tag No. ; Customer specific notes

FLOW TABLES FOR METAL TUBES

Table 11

Pos.	Measuring range for water and liquids										Measuring range for air and gases									
	Recommended combination					Alternative combination					Recommended combination					Alternative combination				
	Max. flow		Pressure loss ^{a)}	Code	Viscosity ^{b)}	Cone-Float-combin.	Pressure loss ^{a)}	Code	Viscosity ^{b)}	Cone-Float-combin.	Max. flow	Pressure loss ^{a)}	Code	Cone-Float-combin.	Pressure loss ^{a)}	Code	Cone-Float-combin.	Pressure loss ^{a)}	Code	
	m ³ /h ^{c)}	gpm ^{d)}	mbar	mPa's	mPa's	mbar	mPa's	mPa's	mPa's	mbar	m ³ /h ^{e)}	scfm ^{f)}	mbar	Code	mbar	Code	Code	mbar	Code	
1	0.025	0.11	40	10	-	-	-	-	-	0.75	0	45	43 S0	45	-	-	-	-	-	
	0.04	0.18	40	80	-	-	-	-	-	1.2	1.1	45	44 S0	45	-	-	-	-	-	
	0.063	0.28	40	80	-	-	-	-	-	1.8	1.7	45	47 S0	45	-	-	-	-	-	
	0.1	0.44	40	80	-	-	-	-	-	3	2.8	45	51 S0	45	-	-	-	-	-	
	0.13	0.57	12	50	-	-	-	-	-	4	3.6	13	53 L1	13	-	-	-	-	-	
	0.16	0.7	-	-	53 M1	15	100	-	-	5.5	5	-	-	-	53 M1	21	-	-	-	
	0.22	1.0	12	50	-	-	-	-	-	-	-	-	-	-	-	-	-	-	-	
	0.25	1.1	40	100	54 M1	15	50	-	-	6.5	6	13	54 L1	13	-	-	-	-	-	
	0.32	1.4	-	-	57 L1	12	50	-	-	9	8.5	-	-	-	54 M1	21	-	-	-	
	0.4	1.8	40	50	57 M1	15	50	-	-	10	9	13	57 L1	13	-	-	-	-	-	
2	0.5	2.2	-	-	61 L1	12	50	-	-	14	13	-	-	-	57 M1	21	-	-	-	
	0.63	2.8	40	50	61 M1	15	100	-	-	16	15	13	61 L1	13	-	-	-	-	-	
	0.8	3.5	-	-	62 L1	12	50	-	-	22	20	-	-	-	61 M1	21	-	-	-	
	1.0	4.4	40	100	62 M1	15	100	-	-	25	23	13	62 L1	13	-	-	-	-	-	
	1.6	7.0	40	100	-	-	-	-	-	34	32	-	-	-	62 M1	21	-	-	-	
	2.2	10.1	-	-	62 V1	45	50	-	-	50	45	-	-	-	62 S1	45	-	-	-	
	1.3	5.7	17	50	-	-	-	-	-	40	36	19	63 L2	19	-	-	-	-	-	
	2.1	9.2	-	-	64 L2	17	50	-	-	50	47	-	-	-	63 M2	23	-	-	-	
	2.5	11.0	42	30	64 M2	17	10	-	-	60	55	19	64 L2	19	-	-	-	-	-	
	4	17.6	42	10	-	-	-	-	-	85	80	-	-	-	64 M2	23	-	-	-	
3	6	26.4	-	-	64 V2	43	50	-	-	120	110	-	-	-	64 S2	47	-	-	-	
	3.2	14	13	50	-	-	-	-	-	100	90	16	67 L5	16	-	-	-	-	-	
	5.0	22	-	-	71 L5	13	50	-	-	130	120	-	-	-	67 M5	25	-	-	-	
	6.3	28	47	30	-	-	-	-	-	160	150	16	71 L5	16	-	-	-	-	-	
	8.5	37	-	-	72 L5	13	50	-	-	200	180	-	-	-	71 M5	25	-	-	-	
	10	44	47	5	72 M5	19	5	-	-	250	230	16	72 L5	16	-	-	-	-	-	
	16	70	47	5	-	-	-	-	-	340	320	-	-	-	72 M5	25	-	-	-	
	25	110	-	-	72 V5	63	5	-	-	500	470	-	-	-	72 S5	54	-	-	-	
	25	110	60	10	-	-	-	-	-	550	500	30	73 L8	30	-	-	-	-	-	
	40	176	60	10	-	-	-	-	-	850	800	30	74 L8	30	-	-	-	-	-	
4	63	277	60	10	-	-	-	-	-	1400	1300	30	77 L8	30	-	-	-	-	-	
	100	440	70	10	-	-	-	-	-	-	-	-	-	-	-	-	-	-	-	
	130	572	70	10	-	-	-	-	-	-	-	-	-	-	-	-	-	-	-	
	5	6																		

a) Pressure loss at the float with water or air.

b) For higher viscosity the specified precision is no more guaranteed.

c) Flow is referred to 20°C and 1 bar abs.

d) Flow in US Gallons per minute at 70°F.

e) Flow referred to 0°C and 1.013 bar abs at operation conditions of 20°C and 1,013 bar abs.

f) Flow in Standard cubic feet per minute referred to 60°F and 14,7 PSI at operation conditions of 70°F and 14,7 PSI abs.

For your special application please use the Rota Yokogawa Sizing-Program.

PROCESS CONNECTION- AND FLOW-TABLE FOR TUBES WITH PTFE LINING

Table 12

Pos.	Process connection						Measuring range for water and liquids						Measuring range for air and gases								
	EN-Flange			ASME-Flange			Max. Flow			Pressure			Max. Flow			Cone-Float-combination			Pressure		
	PN 16 Code	PN40 Code	L ⁽¹⁾	150 lbs Code	L ⁽¹⁾	300 lbs Code	m ³ /h ^(c)	gpm ^(d)	mbar	loss ^(a)	Viscosity ^(b)	m ³ /h ^(e)	m ³ /h I.N. ^(e)	scfm ^(f)	Code	Float-combination	loss ^(a)				
2	D2	D4	mm	A1	mm	A2	0.1	0.45	16	50	50	3.5	3.3	2	51 A1	51 A1	20				
							0.16	0.7	16	50	50	5	4.7	2.9	52 A1	52 A1	20				
							0.25	1.12	16	50	50	8.5	8	5	53 A1	53 A1	20				
			250				0.4	1.8	16	50	50	13	12	7.5	54 A1	54 A1	20				
							0.63	2.8	16	50	50	20	18	11	57 A1	57 A1	20				
							1	4.5	18	50	50	34	32	20	61 V1	61 V1	22				
3							1.6	7	20	30	30	50	47	29	62 A2	62 A2	25				
							2.5	11.2	20	10	10	85	80	50	63 A2	63 A2	25				
							4	18	22	50	50	-	-	-	-	-	-				
							4	18	20	30	30	130	120	75	64 A5	64 A5	25				
4							6.3	28	20	30	30	200	180	115	67 A5	67 A5	25				
							10	45	20	5	5	350	330	200	71 A5	71 A5	25				
							16	70	22	10	10	-	-	-	-	-	-				
							16	70	25	10	10	500	470	290	72 V8	72 V8	27				
5							25	110	25	10	10	850	800	500	73 V8	73 V8	27				
							40	180	25	10	10	-	-	-	-	-	-				
							63	280	30	10	10	-	-	-	-	-	-				
6																					

- (1) L = Mounting length
- a) Pressure loss at the float with water or air.
- b) As from this viscosity the specified precision is no more guaranteed.
- c) Flow is referred to 20°C and 1 bar abs.
- d) Flow in US Gallons per minute at 70°F.
- e) Flow referred to 0°C and 1.013 bar abs at operation conditions of 20°C and 1,013 bar abs.
- f) Flow in Standard cubic feet per minute referred to 60°F and 14,7 PSI at operation conditions of 70°F und 14,7 PSI abs.

For your special application please use the Rota Yokogawa Sizing-Program.

TEMPERATURE GRAPHS FOR RAMC METAL DESIGN, STANDARD AND INTRINSIC SAFE

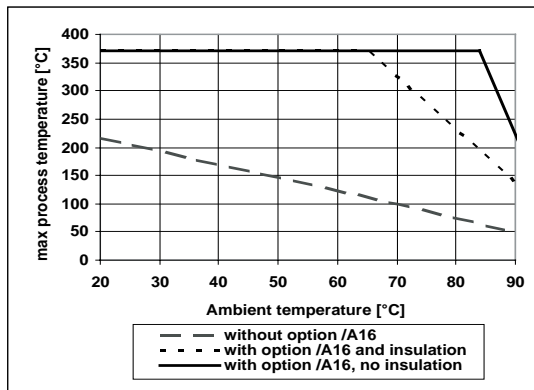

fig. 7a RAMC : - type 90 / 91
- only with indicator

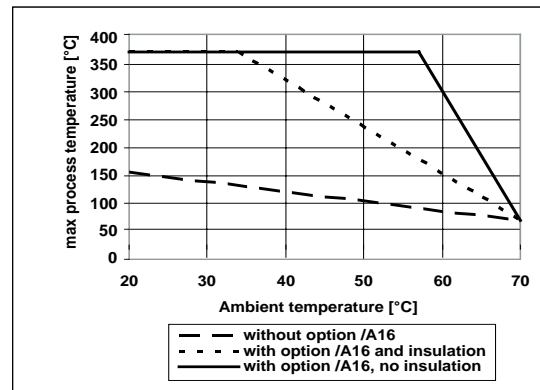

fig. 7b RAMC : - type 90 / 91
- with limit switches
- with electronic transmitter

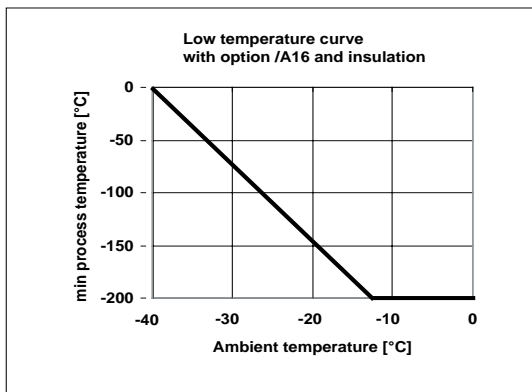

fig. 7c RAMC : - type 90 / 91
- with or without limit switches
- with or without electronic transmitter

T10.EPS

The temperature graphs are reference values for size DN100. They may be influenced negative by trapped heat, external heat sources or radiated heat and influenced positive for smaller sizes.

Insulation means rock wool between tube and indicator.

Units with electronic transmitter can show the temperature of the internal transmitter on the display or HART- type can show and supervise the internal temperature by HART-communication.

Units with PTFE lining are usable up to 130°C.

For units with explosion proof certification the temperature limits according the certificate of conformity must be regarded (see also page 4 to 6).

Minimum ambient temperatures:

Flow meter	Model code	Minimum ambient temperature
RAMC with local indicator	RAMCxx-xxxx-xxxx-TxxNNN	-25°C; -40°C with option /A26 *)
RAMC with standard limit switches	RAMCxx-xxxx-xxxx-xxxxxx /K1.../K3	-25°C
RAMC with fail safe limit switches /K6.../K8	RAMCxx-xxxx-xxxx-xxxxxx /K6.../K8	-25°C; -40°C with option /A26 *)
RAMC with fail safe limit switches /K9.../K10	RAMCxx-xxxx-xxxx-xxxxxx /K9.../K10	-25°C
RAMC with electronic transmitter	RAMCxx-xxxx-xxxx-Exx1xx	-25°C
	RAMCxx-xxxx-xxxx-Exx2xx	-25°C
	RAMCxx-xxxx-xxxx-Exx4xx	-25°C; -40°C with option /A26 *)
	RAMCxx-xxxx-xxxx-Hxx4xx	-25°C; -40°C with option /A26 *)
RAMC with electronic transmitter PA	RAMCxx-xxxx-xxxx-Gxx429	-25°C
RAMC intrinsic safe type	RAMCxx-xxxx-xxxx-xxxxxx /KS1	-25°C; -40°C with option /A26 *)
	RAMCxx-xxxx-xxxx-xxxxxx /KS1 /K1.../K3	-25°C
	RAMCxx-xxxx-xxxx-xxxxxx /KS1 /K6.../K8	-25°C; -40°C with option /A26 *)
	RAMCxx-xxxx-xxxx-xxxxxx /KS1 /K9.../K10	-25°C
	RAMCxx-xxxx-xxxx-xxxxxx /KS3	-25°C; -40°C with option /A26 *)
	RAMCxx-xxxx-xxxx-xxxxxx /KS3 /K1.../K3	-25°C
	RAMCxx-xxxx-xxxx-xxxxxx /KS3 /K6.../K8	-25°C; -40°C with option /A26 *)
	RAMCxx-xxxx-xxxx-xxxxxx /KS3 /K9.../K10	-25°C
	RAMCxx-xxxx-xxxx-xxxxxx /KN1	-25°C; -40°C with option /A26 *)
	RAMCxx-xxxx-xxxx-xxxxxx /KN1 /K1.../K3	-25°C
	RAMCxx-xxxx-xxxx-xxxxxx /KN1 /K6.../K8	-25°C; -40°C with option /A26 *)
	RAMCxx-xxxx-xxxx-xxxxxx /KN1 /K9.../K10	-25°C
	RAMCxx-xxxx-xxxx-xxxxxx /ES1	-25°C; -40°C with option /A26 *)
	RAMCxx-xxxx-xxxx-xxxxxx /ES1 /K1.../K3	-25°C;
	RAMCxx-xxxx-xxxx-xxxxxx /ES1 /K6.../K8	-25°C; -40°C with option /A26 *)
	RAMCxx-xxxx-xxxx-xxxxxx /ES1 /K9.../K10	-25°C
RAMCxx-xxxx-xxxx-xxxxxx /ES3	-25°C; -40°C with option /A26 *)	
RAMCxx-xxxx-xxxx-xxxxxx /FS1 /....	-25°C	
RAMCxx-xxxx-xxxx-xxxxxx /CS1 /....	-25°C	
RAMCxx-xxxx-xxxx-xxxxxx /NS1 /....	-25°C	
RAMC flame proof or dust proof type	RAMCxx-xxxx-xxxx-xxxxxx /KF1 /....	-20°C
	RAMCxx-xxxx-xxxx-xxxxxx /EF1 /....	
	RAMCxx-xxxx-xxxx-xxxxxx /NF1 /....	
	RAMCxx-xxxx-xxxx-xxxxxx /KS2 /....	
	RAMCxx-xxxx-xxxx-xxxxxx /ES2 /....	

*) Below -25°C the LC-display will not work. Also the push buttons should not be used below -25°C !

DIMENSIONS AND WEIGHTS

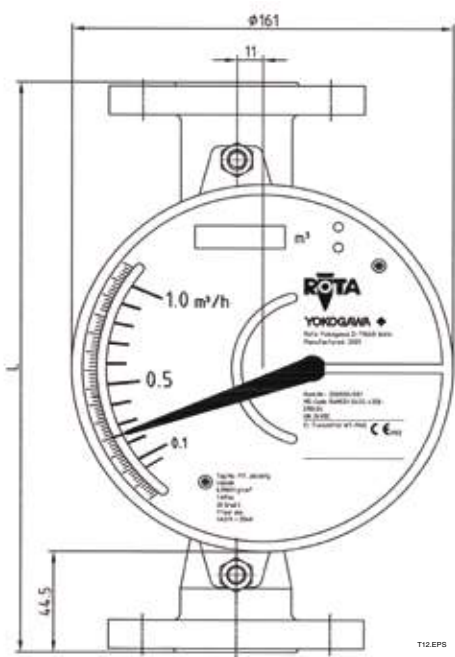

fig. 8a Front view housing type 90

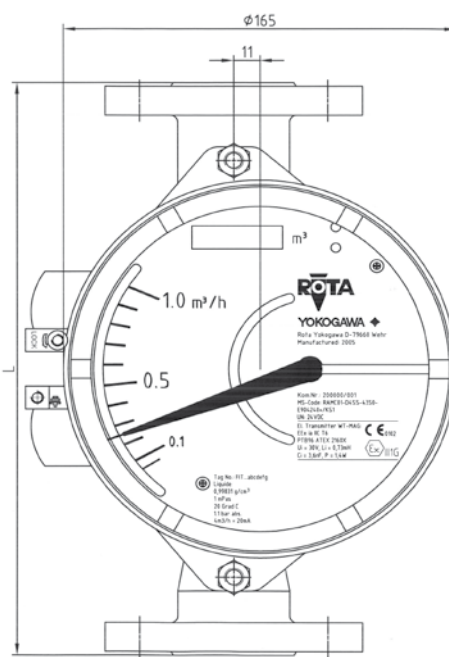

fig. 8b Front view housing type 91

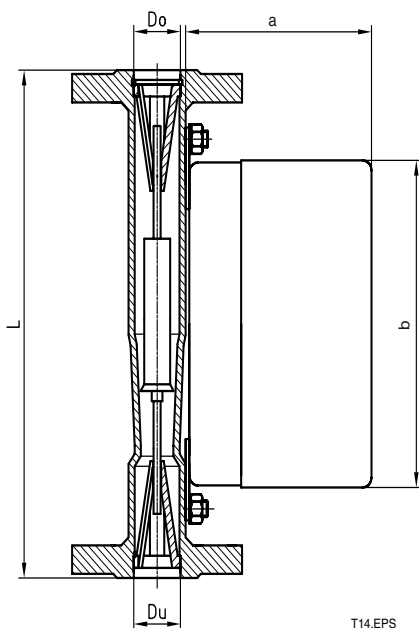

fig. 9 Metal version

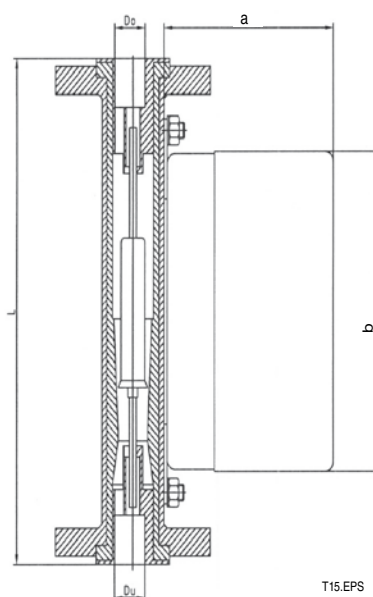

fig. 10 Metal version with lining

	a mm	b mm
Housing type 90	104	161
Housing type 91 standard	110	165
Housing type 91 flame proof , option /KF1	118	165

Table 13

Inner diameter of stainless steel flanges								Inner diameter of flanges with PTFE- lining			
Pos. ¹⁾	EN-flange without groove			ASME-flange			Rosita-flange	Pos. ¹⁾	EN- flange	ASME-flange	Du = Do mm
	Size	Du mm	Do mm	Size	Du mm	Do mm	Du=Do mm		Size	Size	
1	DN15-DN50	20.7	20.7	½'' - 1''	20.7	20.7	20.7	----	----	----	----
2	DN15-DN50	29.5	29.5	½''	20.7	20.7	29.5	2	DN15-DN25	¾'' - 1''	23.5
				¾'' - 2''	29.5	29.5					
3	DN25-DN50	45.2	45.2	1''	32.2	32.2	45.2	3	DN25-DN50	1¼'' - 1½	36.0
				1¼'' - 2''	45.2	45.2					
4	DN50-DN100	62.0	76.0	2''	62.0	65.5	----	4	DN50-DN80	2½'' - 3''	66.0
				2½'' - 3''	62.0	76.0					
5	DN80-DN150	94.0	94.0	3'' - 6''	94.0	94.0	----	5	DN80-DN100	3½'' - 4''	82.0
6	DN100-DN150	116.0	116.0	4'' - 6''	116.0	116.0	----	6	DN100	4''	110.0

¹⁾ see table 10, 11, 12

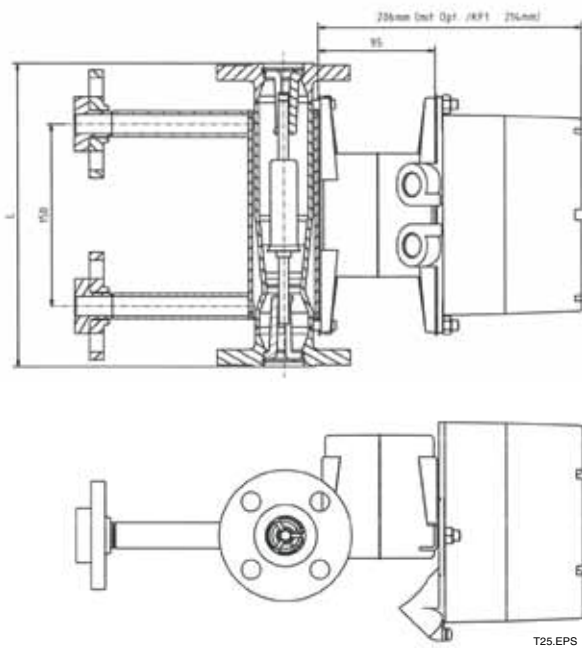

fig. 11 RAMC type 91 and Option /A16 and T2

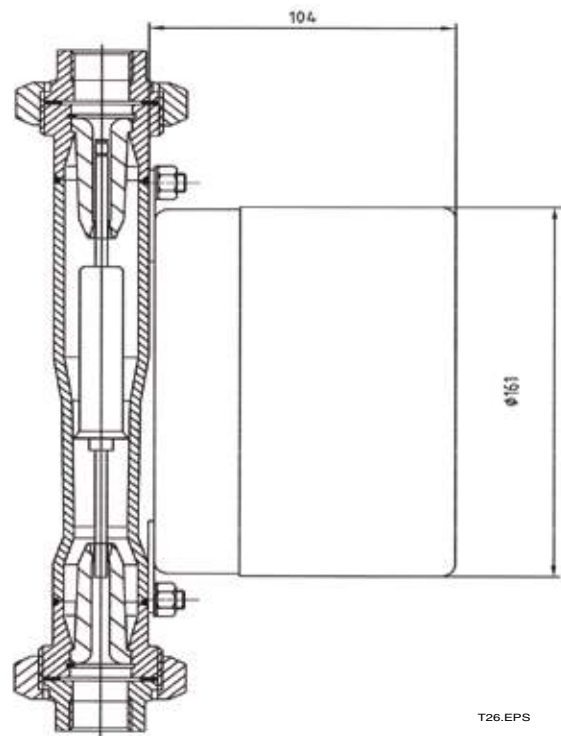

fig. 12 RAMC with connection R4/ T4

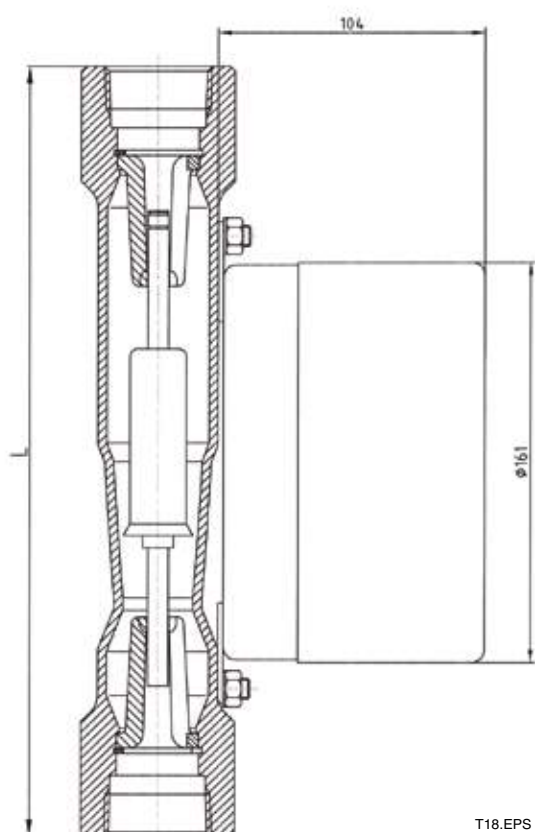

fig. 13 RAMC with connection T6/ G6

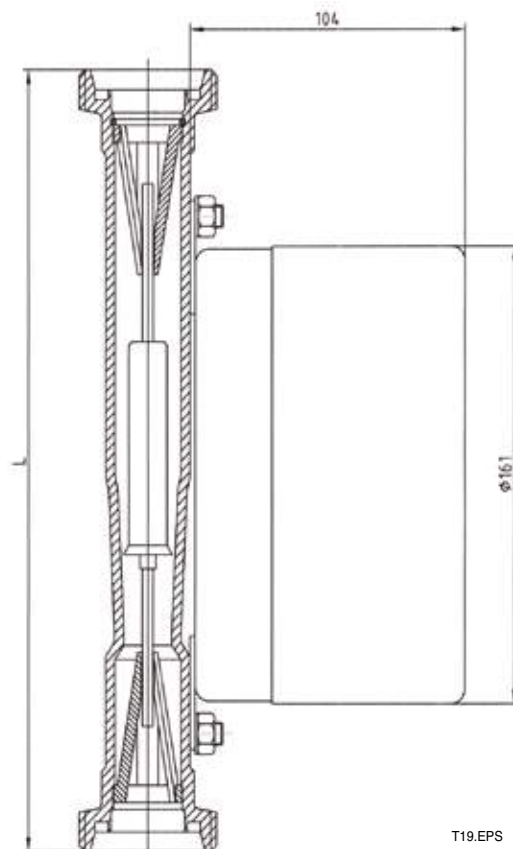

fig. 14 RAMC with connection S2

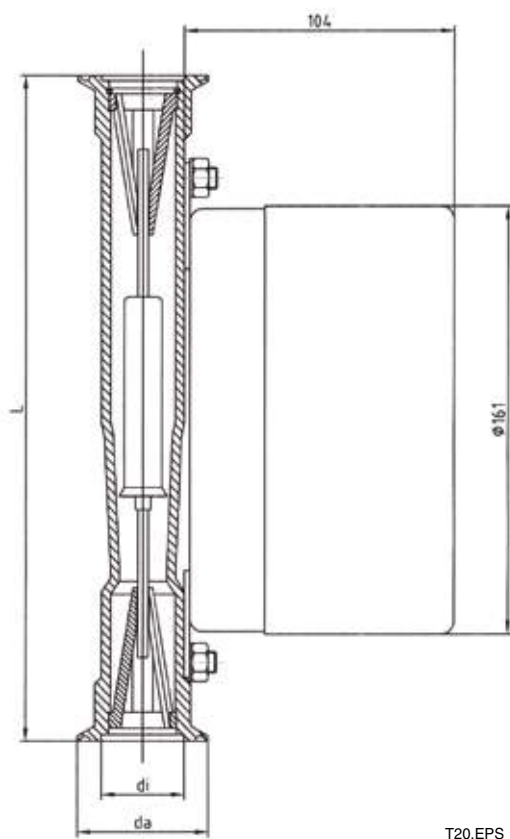

fig. 15 RAMC with connection S4

Table 14 Diameter for connection sizes S4

Position *)	Size [mm]	d_i [mm]	d_a [mm]
1	DN25 / 1''	36	50.5
	DN32	36	50.5
	DN40 / 1 1/2''	36	50.5
2	DN25 / 1''	36	50.5
	DN32	36	50.5
	DN40 / 1 1/2''	36	50.5
3	DN50 / 2''	47.8	64
4	DN65 / 3''	72.1	91
5	DN100 / 4''	97.6	119

*) see table 10, 11, 12

Table 15 Weights

Position *)	Weight [kg]
1	3 - 5
2	3 - 5
3	6.5 - 8
4	8.6 - 11
5	13 - 16
6	17 - 20

*) see table 10, 11, 12

Indicator on distance (option /A16) additional 1kg

	<p>Yokogawa has an extensive sales and distribution network. Please refer to the European website (www.yokogawa.com/eu) to contact your nearest representative.</p>  <p>YOKOGAWA ◆</p>
--	--

Rotameter™ is a trademark of Rota Yokogawa GmbH & Co. KG, a subsidiary of Yokogawa Electric Corporation, Japan. In the United Kingdom Rotameter™ is a trademark of Emerson Electric Co.