

**(DMF) 8, 15, 20 E 30 UNIDADES; 3000G E 8000G DE CAPACIDADE**

8, 15, 20 and 30 units; 3000g and 8000g of dough capacity / 8, 15, 20 y 30 piezas; 3000g y 8000g de capacidad de masa / 8, 15, 20 et 30 pièces; 3000g et 8000g de capacité de pâte / 8, 15, 20 und 30 Einheiten; Teigkapazität von 3000g und 8000g

**(DMQ) 5, 8, 10 E OUTRAS UNIDADES CONFORME TABELA; 8000G DE CAPACIDADE**

5, 8, 10 and other units according to the table; 8000g of dough capacity / 5, 8, 10 y otras unidades de acuerdo con la tabla; 8000g de capacidad de masa / 5, 8, 10 et autres unités, conformément au tableau; 8000g de capacité de pâte / 5, 8, 10 und andere Einheiten gemäß Tabelle; Teigkapazität von 8000g

**(DMQ) POSSIBILIDADE DE TROCA DE PRENSA**

(DMQ) Possibility to change the press / (DMQ) Posibilidad de sustitución de prensa / (DMQ) Possibilité de remplacer la tête / (DMQ) Austauschbare Presse

**LÂMINAS DE CORTE CONSTRUÍDAS EM AÇO INOXIDÁVEL AISI304**

Stainless steel AISI304 knives / Láminas de corte construídas em aço inoxidável AISI304 / Lame en acier inoxydable AISI304 / Schneidmesser aus Edelstahl AISI304

**FÁCIL ABERTURA DA MÁQUINA PARA LIMPEZA**

Easy opening of the top of the machine for cleaning / Fácil apertura de la cabeza de la máquina para limpieza / Facile ouverture de la machine pour aseptisation / Leichtes Öffnen der Maschine zur Reinigung

DMF  
DMQ

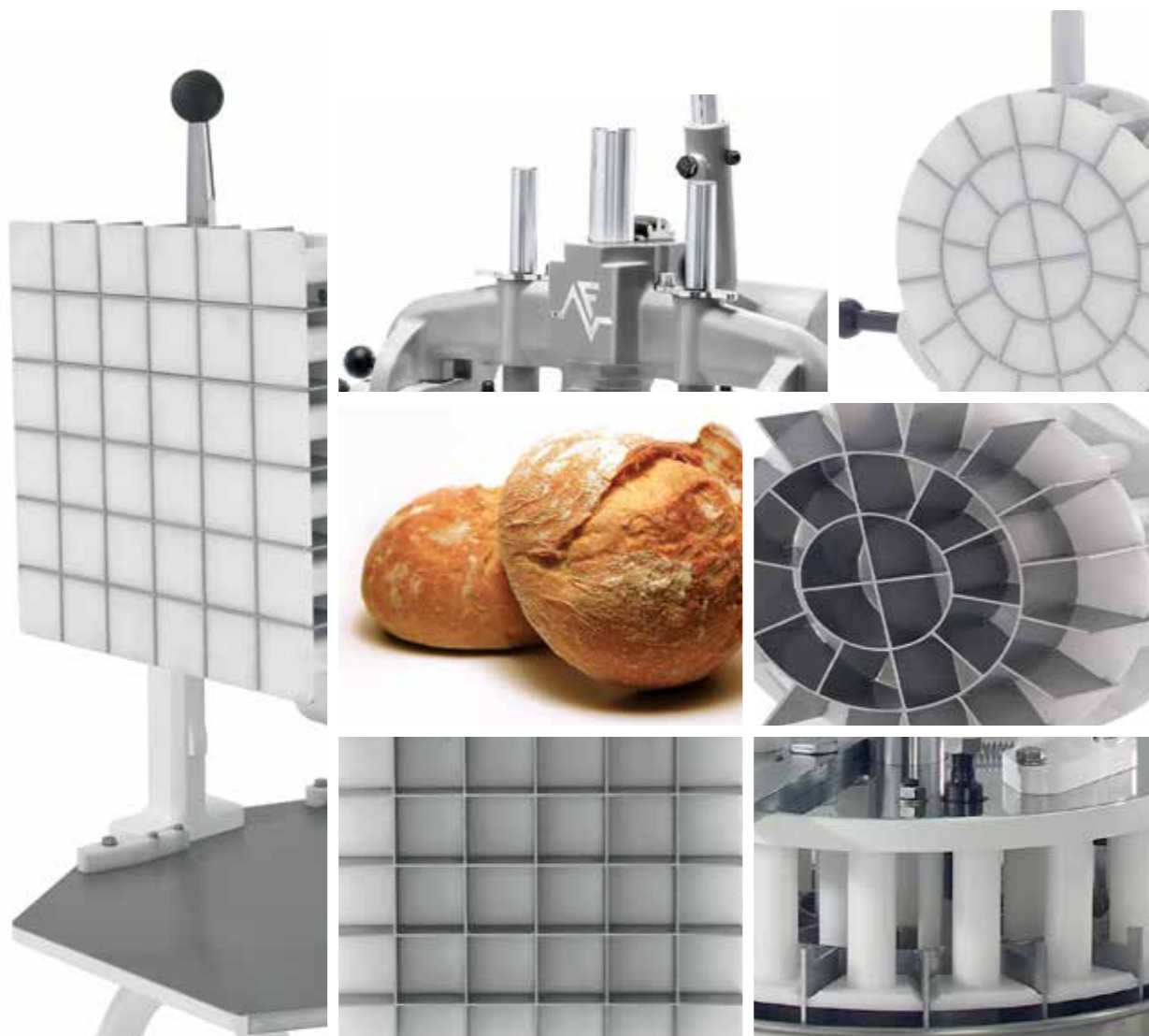

*Innovation with Passion*

A informação contida neste catálogo pode conter erros tipográficos ou fotográficos, ser alterada sem aviso prévio e carece de confirmação por parte da empresa Fernetto S.A. / The information contained in this catalogue may contain typing or photographic errors and may be altered without prior warning. It lacks confirmation by the company Fernetto S.A. / La información contenida en este catálogo puede contener errores tipográficos o fotográficos, se podrá modificar sin previo aviso y carece de confirmación de la empresa Fernetto S.A. / Les informations figurant dans ce catalogue sont susceptibles de contenir des erreurs typographiques ou photographiques, elles pourront être modifiées sans préavis et elles n'ont pas été confirmées par l'entreprise Fernetto S.A. / Die in diesem Katalog enthaltenen Informationen können typographische oder fotografische Fehler beinhalten, ohne vorherige Ankündigung geändert werden und bedürfen noch der Bestätigung durch das Unternehmen Fernetto S.A.

**(DMF) DIVISORA MANUAL**

MANUAL DIVIDER / DIVISORA MANUAL / DIVISEUSE MANUELLE / TEIGTEILMASCHINE

**(DMQ) DIVISORA MANUAL QUADRADA**

MANUAL SQUARE DIVIDER / DIVISORA MANUAL CUADRADA / DIVISEUSE CARRÉE MANUELLE / QUADRATTEIGTEILMASCHINE

[standard]

[inox]

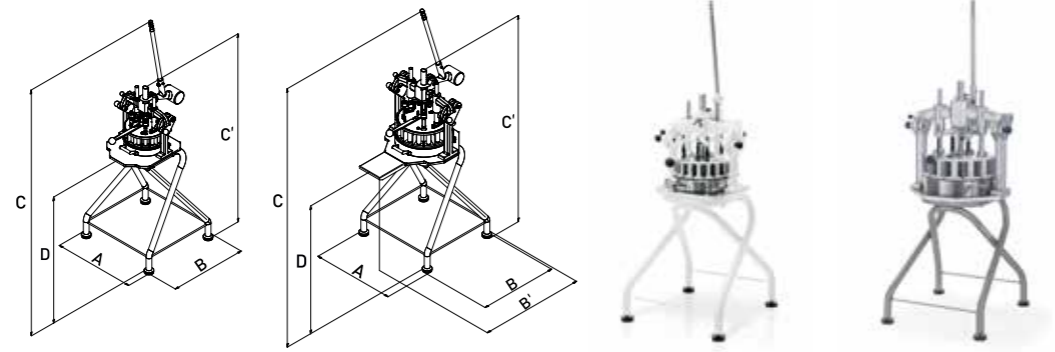

CC_009-10		DMF315	DMF330	DMF808	DMF815	DMF820	DMF830
PEÇAS (un) Pieces / Piezas / Pièces / Stücke		15	30	8	15	20	30
PESO EMPÊLO* (g)-(lb) Dough weight* / Peso masa* / Poids pâton* / Teigeinlage*	MIN.	750 (1,65)	750 (1,65)	900 (1,98)	900 (1,98)	900 (1,98)	900 (1,98)
	MAX.	3000 (6,61)	3000 (6,61)	8000 (17,64)	8000 (17,64)	8000 (17,64)	8000 (17,64)
PESO PEÇA* (g)-(lb) Weight of dough pieces* / Peso pieza* / Poids pièces* / Gewicht der Teigstücke*	MIN.	50 (0,11)	25 (0,06)	113 (0,25)	60 (0,13)	45 (0,10)	30 (0,07)
	MAX.	200 (0,44)	100 (0,22)	1000 (2,20)	533 (1,18)	400 (0,88)	267 (0,59)
PESO LÍQUIDO (kg)-(lb) Net weight / Peso neto / Poids net / Nettogewicht		† 108 (238,10) X 95,5 (210,54)	108 (238,10) 95,5 (210,54)	147 (324,08) 134,5 (296,52)	147 (324,08) 134,5 (296,52)	147 (324,08) 134,5 (296,52)	147 (324,08) 134,5 (296,52)
	A	† 680 (26 3/4) X 580 (22 13/16)	680 (26 3/4) 580 (22 13/16)	700 (27 9/16) 685 (26 15/16)	700 (27 9/16) 685 (26 15/16)	700 (27 9/16) 685 (26 15/16)	700 (27 9/16) 685 (26 15/16)
	B	670 (26 3/8)	670 (26 3/8)	670 (26 3/8)	670 (26 3/8)	670 (26 3/8)	670 (26 3/8)
	B'	-	-	900 (35 7/16)	900 (35 7/16)	900 (35 7/16)	900 (35 7/16)
DIMENSÕES (mm)-(in) Dimensions / Dimensiones / Dimensions / Dimensionen	C	† 1730 (68 1/8) X 923 (36 5/16)	1730 (68 1/8) 923 (36 5/16)	1820 (71 5/8) 1013 (39 7/8)	1820 (71 5/8) 1013 (39 7/8)	1820 (71 5/8) 1013 (39 7/8)	1820 (71 5/8) 1013 (39 7/8)
	C'	† 1230 (48 7/16) X 525 (36 5/16)	1230 (48 7/16) 525 (36 5/16)	1340 (52 3/4) 640 (25 3/16)	1340 (52 3/4) 640 (25 3/16)	1340 (52 3/4) 640 (25 3/16)	1340 (52 3/4) 640 (25 3/16)
	D	710 (27 15/16)	710 (27 15/16)	710 (27 15/16)	710 (27 15/16)	710 (27 15/16)	710 (27 15/16)

\* As capacidades mínima e máxima variam consoante a fermentação / Maximum and minimum capacities depends on fermentation / Las capacidades máximas y mínimas pueden variar dependiendo de la fermentación de la masa / Les capacités minimum et maximum changent selon la fermentation / Die minimale und maximale Kapazität variieren je nach Gärung;

\*\* Baseado em massas diretas com hidratação a 90% / Based on straight dough ("direct dough") with 90% hydration / Basado en masas directas con un 90 % de hidratación / Basé sur des pâtes directes avec 90% d'hydratation / Auf Grundlage von direkten Teigen mit 90% Hydratation;

[standard] estrutura em aço carbono pintada / White painted carbon steel frame / Estructura en acero carbono pintada en blanco / Bâti en acier au carbone / Konstruktion in unlegiertem lackierten Stahl in weiß lackiert;

[inox] cabeça e arco da máquina em ferro fundido pintado na cor cinza e base em aço inoxidável / The machine's head and arch are made from cast iron, painted grey, with a stainless steel base / Cabeza y arco de la máquina en hierro fundido pintado en color gris y base en acero inoxidable / Tête et arc de la machine en fonte de couleur grise et base en acier inoxydable / Maschinenkopf und -bogen aus grau lackiertem Gusseisen und Boden aus Edelstahl

† Com base-pés / With structure-feet / Con base-pies / Avec structure-pied / Mit Struktur-Füße;  
X Sem base-pés / Without structure-feet / Sin base-pies / Sans structure-pied / Mit Struktur-Füße

[standard]

[inox]

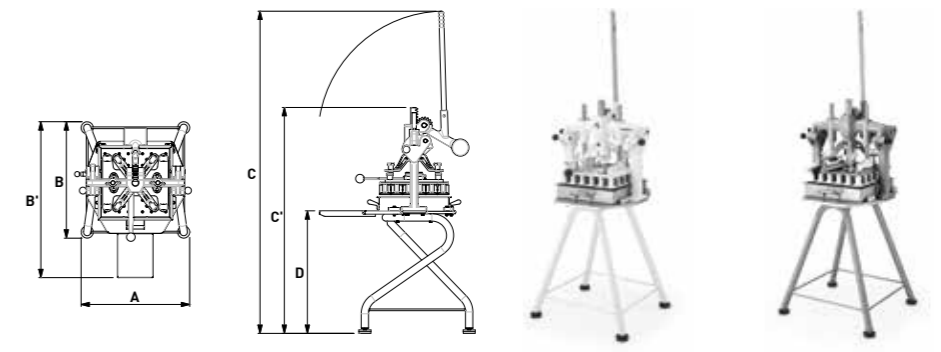

CC_009-10		DMQ8xx
PESO LÍQUIDO (kg)-(lb) Net weight / Peso neto / Poids net / Nettogewicht		† 147 (324,08) X -
	A	† 700 (27 9/16) X -
	B	670 (26 3/8)
	B'	900 (35 7/16)
DIMENSÕES (mm)-(in) Dimensions / Dimensiones / Dimensions / Dimensionen	C	† 1820 (71 5/8) X -
	C'	† 1820 (71 5/8) X -
	D	710 (27 15/16)

CC_009-10	DIMENSÕES (mm)-(in) Dimensions / Dimensiones / Dimensions / Dimensionen		PDQ.xxx.yyy	PEÇAS (un)** Pieces / Piezas / Pièces / Stücke
	XXX	YYY		
	400	80	PDQ.400.80	5
	200	100	PDQ.200.100	8
	200	80	PDQ.200.80	10
	200	65	PDQ.200.65	12
	200	55	PDQ.200.55	14
	200	50	PDQ.200.50	16
	130	80	PDQ.130.80	15
	130	65	PDQ.130.65	18
	130	55	PDQ.130.55	21
	130	50	PDQ.130.50	24
	100	80	PDQ.100.80	20
	100	65	PDQ.100.65	24
	100	55	PDQ.100.55	28
	100	50	PDQ.100.50	32
	100	40	PDQ.100.40	40
	80	80	PDQ.80.80	25
	80	65	PDQ.80.65	30
	80	55	PDQ.80.55	35
	80	50	PDQ.80.50	40
	65	65	PDQ.65.65	36
	55	55	PDQ.55.55	49
	50	50	PDQ.50.50	64
	40	40	PDQ.40.40	100

PDQ.xxx.yyy  
- xxx = altura /  
- yyy = largura /